



PY32F403 Datasheet

32-bit ARM® Cortex™-M4 Microcontroller



Puya Semiconductor (Shanghai) Co., Ltd



Features

- Cores and Systems
 - 32-bit ARM® Cortex™-M4 processor core with FPU and DSP instruction support
 - Typical operating frequency up to 144 MHz
- Memory
 - Up to 384 Kbytes of flash program memory
 - Up to 64 Kbytes of SRAM
- Clock, reset and power management
 - 1.8 V ~ 3.6 V supply
 - Power-on/power-off reset (POR/PDR), programmable voltage monitor (PVD)
 - External 4 ~ 32 MHz high-speed crystal oscillator
 - Built-in factory-tuned 8 MHz high-speed oscillator
 - PLL supports CPU operation at up to 144 MHz
 - External 32.768 kHz low-speed oscillator
- Low power consumption
 - Sleep, shutdown and standby modes
 - V_{BAT} to power RTC and back-up registers
- 3 x 12-bit analogue-to-digital converters, 1 μ s conversion time (up to 18 input channels)
 - Conversion range: 0 ~ V_{CCA}
 - Support for sample time and resolution configuration
 - Supports single, continuous, sweep and discontinuous conversion modes
 - On-chip temperature sensor
 - On-chip voltage sensor
- 2 x 12-bit digital-to-analog converters
 - Output range: 0 ~ V_{REF+}
 - Independent output channels
 - Support Timer, EXTI triggering
- 12 - channel DMA controller
 - Supported peripherals: Timer, ADC, UART, I²C, I2S, SPI, SDIO
- Up to 80 fast I/O ports:
 - All I/O ports can be imaged to 16 external interrupts
 - Some ports support 5 V input
- Debug modes
 - Serial Single Wire Debug (SWD) or JTAG interface
- Up to 17 timers
 - 2 x 16-bit advanced control timers with 4 channels of PWM outputs, as well as deadband generation and emergency stop functions
 - 10 16-bit general purpose timers with up to 4 independent channels for input capture/output comparison, the general purpose timers also support an encoder interface for two inputs using a quadrature decoder
 - 2 x 16-bit basic timers
 - 2 watchdog timers (standalone and windowed)
 - System time timer: 24-bit self-subtracting counter
- Up to 13 communication interfaces
 - 5 UART interfaces
 - 2 I²C interfaces
 - 3 SPI interfaces
 - 1 ESMC interface
 - 1 CANFD interface
 - 1 USB interface
 - 1 SDIO interface
- 96-bit unique chip ID (UID)
- In LQFP100, LQFP64, LQFP48, QFN48, QFN32(4*4) packages

Contents

Features	2
1. Introduction	6
2. Overview of functions	9
2.1. Arm® Cortex®-M4 processor	9
2.2. Memory	9
2.3. Memory Protection Unit (MPU)	10
2.4. FLASH Accelerator (ACC)	10
2.5. Boot mode.....	10
2.6. Backup register (BKP)	10
2.7. Clock system.....	11
2.8. Power Management.....	13
2.8.1. Power supply block diagram	13
2.8.2. Power monitoring.....	14
2.8.3. Voltage regulator	15
2.8.4. Low power modes	15
2.9. Reset.....	15
2.9.1. Power Reset	15
2.9.2. System Reset	16
2.10. General purpose input and output GPIOs.....	16
2.11. DMA	16
2.12. Interrupt	17
2.12.1. Interrupt Controller NVIC.....	17
2.12.2. Extended Interrupt EXTI.....	17
2.13. Analog-to-digital converter ADCs.....	18
2.14. Timer	18
2.14.1. Advanced Timer	18
2.14.2. General purpose timers.....	19
2.14.3. Basic Timer TIM6/TIM7	19
2.14.4. IWDG.....	20
2.14.5. WWDG	20
2.14.6. SysTick timer	20
2.15. Real Time Clock RTC	20
2.16. Cyclic Redundancy Check Calculation Unit CRC	21
2.17. Clock Calibration System CTC.....	21
2.18. System Configuration Controller SYSCFG	21
2.19. Debug support (DBG)	21
2.20. SDIO.....	22
2.21. I ² C interface.....	22

2.22.	Universal Synchronous Asynchronous Transceiver USART	23
2.23.	Serial Peripheral Interface SPI	24
2.24.	Internal integrated audio (I2S).....	25
2.25.	External Serial Memory Controller (ESMC)	25
2.26.	USB 2.0 Full Speed Module	25
2.27.	CANFD	26
2.28.	SWD	27
3.	Pin Configuration.....	28
3.1.	Port A multiplexed function mapping	39
3.2.	Port B multiplexed function mapping	39
3.3.	Port C multiplexing function mapping	40
3.4.	Port D multiplexing function mapping	41
3.5.	Port E multiplexing function mapping	41
4.	Memory Map.....	43
5.	Electrical Characteristics.....	47
5.1.	Parameter conditions	47
5.1.1.	Minium and maximum values	47
5.1.2.	Typical values.....	47
5.2.	Absolute maximum ratings.....	47
5.3.	Operating conditions	48
5.3.1.	General working conditions	48
5.3.2.	Operating conditions at power-up / power-down.....	49
5.3.3.	Reset and vottage control module features.....	49
5.3.4.	Operating current characteristics	49
5.3.5.	Low power mode wake-up time.....	52
5.3.6.	External clock source characteristics	52
5.3.7.	Internal high frequency clock source HSI characteristics	55
5.3.8.	Internal low frequency clock source LSI characteristics	55
5.3.9.	Phase locked loop (PLL) characteristics	56
5.3.10.	Memory characteristics	56
5.3.11.	ESMC characteristics	56
5.3.12.	EMC characteristics	57
5.3.13.	ESD & LU characteristics	59
5.3.14.	I/O current injection characteristics	59
5.3.15.	EFT characteristics.....	59
5.3.16.	Port Characteristics	59
5.3.17.	NRST pin characteristics.....	61
5.3.18.	ADC characteristics	61
5.3.19.	Temperature sensor characteristics	63
5.3.20.	Built-in reference voltage characteristics	63

5.3.21. Timer characteristics	63
5.3.22. Communication port characteristics	64
5.3.23. SD/SDIO MMCCard host interface characteristics	69
5.3.24. CANFD Interface characteristics	70
6. Package Information	71
6.1. LQFP100 Package Size.....	71
6.2. LQFP64 Package Size.....	72
6.3. LQFP48 Package Size.....	73
6.4. QFN48 Package Size	74
6.5. QFN32 (4*4) Package Size.....	75
7. Ordering Information.....	76
8. Updated History	77

1. Introduction

The PY32F403 series microcontrollers are high performance 32-bit ARM® Cortex®-M4 core MCUs with up to 384 Kbytes flash and 64 Kbytes SRAM memory and a maximum operating frequency of 144 MHz. Multiple I²C, SPI and USART communication peripherals, 3 x 12-bit ADCs, 17 timers, 1 x USB 2.0 and 1 x CANFD are integrated.

The PY32F403 series microcontrollers are available in the operating temperature range of - 40 °C to 85 °C and the operating voltage range of 1.8 V to 3.6 V. The chips provide sleep, stop and standby low power modes to meet different low power applications.

The PY32F403 series microcontrollers are suitable for a wide range of applications such as controllers, handheld devices, PC peripherals, gaming and GPS platforms, industrial applications, etc.

Table 1-1 PY32F403 series planning and features

Peripherals		PY32F403 V1DT	PY32F403 R1DT	PY32F403 R2DT	PY32F403 R1CT	PY32F403 C1BT	PY32F403 C1CT	PY32F403 C1DT	PY32F403 C2DT	PY32F403 C1CU	PY32F403 K1BU	PY32F403 K1CU	
Flash (Kbytes)		384	384	384	256	128	256	384	384	256	128	256	
SRAM (Kbytes)		64	64	64	64	64	64	64	64	64	32	64	
Timers	General timer							10					
	Advanced timer							2					
	SysTick							1					
	Basic timer							2					
	Watch dog							2					
Communication Port	USART	5	5	5	5	3	3	3	3	2	2	2	
	I ² C	2	2	2	2	2	2	2	2	1	1	1	
	SPI	3	3	2	3	3	3	3	3	3	2	2	
	I2S	3	2	3	2	1	1	1	3	1	1	1	
	CANFD	1	1	1	1	1	1	1	1	1	-	-	
	USB	1											
	SDIO	1	1	1	1	1	1	1	1	1	1	-	-
DMA		12ch											
RTC		Yes											
GPIO		80	51	49	51	37	37	37	37	41	26	26	
ESMC		1											
EXTI		16											
ADC (Channels)		3 (16)	3 (16)	3 (16)	3 (16)	3 (10)	3 (10)	3 (10)	3 (10)	3 (11)	3 (10)	3 (10)	
Operating Voltage		1.8 ~ 3.6 V											
Max. CPU frequency		144 MHz											
Operating Temperature		- 40 ~ 85 °C											
Package		LQFP100		LQFP64			LQFP48			QFN48		QFN32	

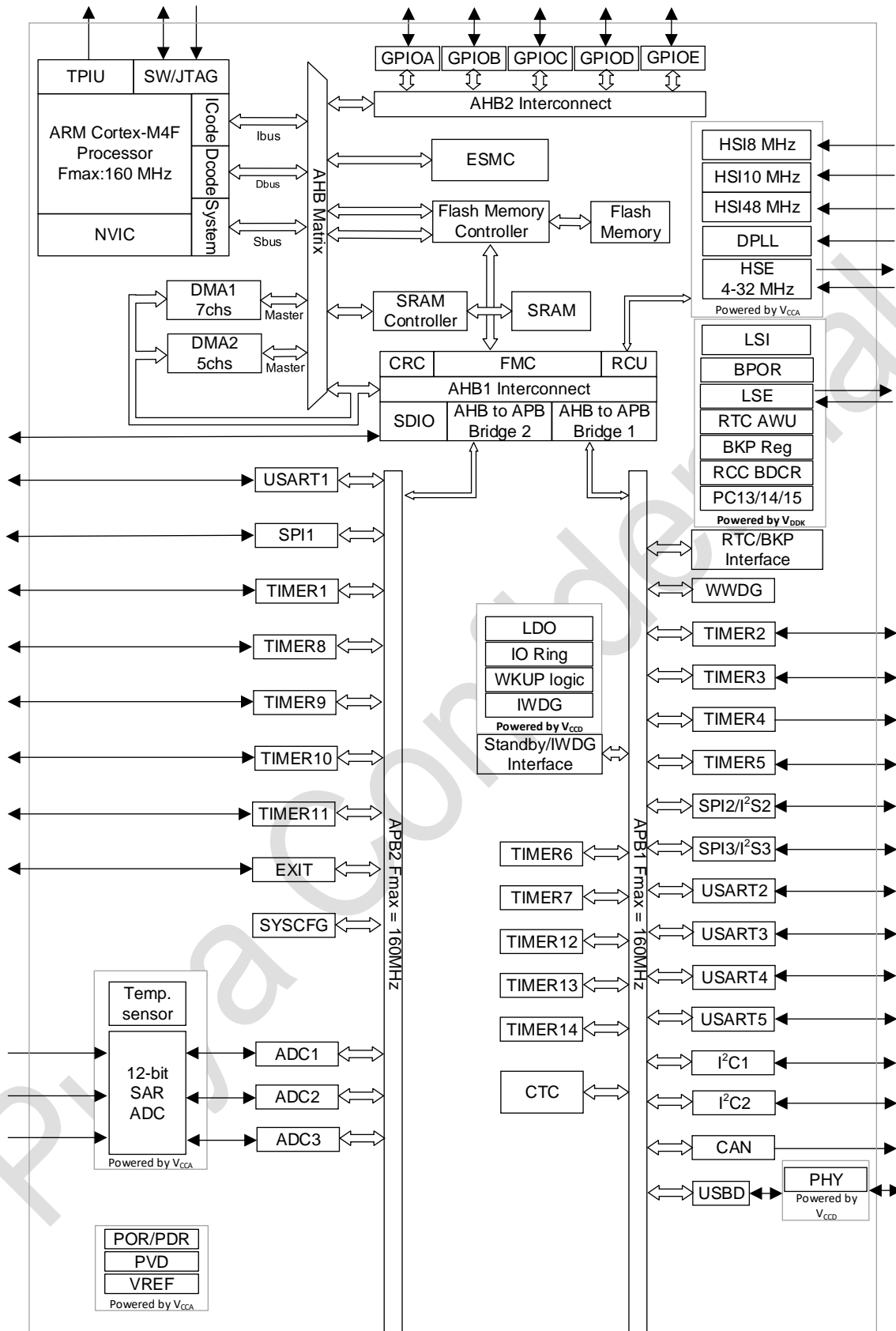

Figure 1-1 Functional modules

2. Overview of functions

2.1. Arm® Cortex®-M4 processor

ARM®'s Cortex®-M4 processor is a high performance embedded 32-bit RISC processor supporting DSP instructions and FPU floating point operations, offering excellent code efficiency and the high performance of the ARM core using the memory space normally available in 8 and 16-bit devices. The processor supports a set of DSP instructions that enable efficient signal processing and complex algorithm execution. Its single precision FPU (floating point unit) accelerates development and prevents saturation through the use of meta-language development tools. Provides a low cost platform for MCUs, low pin count, low power consumption, while providing excellent computational performance and advanced interrupt system response. Compatible with all ARM tools and software.

Cortex®-M4 processor for 32-bit ARM®

- supports 144 MHz operation
- single-cycle multiplier and hardware divider
- Integrated DSP instructions
- Nested interrupt vector control
- 24-bit system tick timer

The ARM® Cortex®-M4 processor is based on the ARMv7-M architecture and supports the Thumb and Thumb-2 instruction sets.

- Internal bus matrix connecting the I-Code bus, D-Code bus, system bus, private peripheral bus (PPB) and debug access (AHB-AP)
- Nested Vector Interrupt Controller (NVIC)
- Flash Patches and Breakpoints (FPB)
- Data Watchpoint and Trace (DWT)
- Instrumentation Trace Macrocell (ITM)
- Serial Line JTAG Debug Port (SWJ-DP)
- Trace Port Interface Unit (TPIU)
- Floating Point Unit (FPU)
- Memory Protection Unit (MPU)

2.2. Memory

The on-chip SRAM is accessible by bytes (8 bits), half - word (16 bits) or word (32 bits).

The on-chip Flash is integrated and consists of two different physical areas:

- Main flash area, which contains application and user data
- Information area, 24 Kbytes, which contains the following sections:
 - Option bytes

- UID bytes
- System memory

The protection of the Flash main memory consists of the following mechanisms:

- Read protection (RDP) to prevent access from outside.
- Write protection (WRP) control, to prevent unwanted write operations (due to confusion of the program memory pointer PC). The minimum protection unit for write protection is 8 Kbytes.
- Option byte write protection, specially designed for unlocking.

2.3. Memory Protection Unit (MPU)

The Memory Protection Unit (MPU) is used to manage CPU access to memory and to prevent one task from accidentally damaging memory or resources used by another active task. This memory area is organized into up to 8 protected areas, which can also be subdivided into up to 8 sub areas in turn. The size of the protected area can be from 32 bytes up to the entire 4G bytes of addressable memory. The MPU is particularly useful if there is critical or certified code in the application that must be protected from the misbehavior of other tasks. It is usually managed by an RTOS (Real Time Operating System). If a program accesses a memory location that is prohibited by the MPU, the RTOS can detect it and take action. In an RTOS environment, the kernel can dynamically update the settings of the MPU area based on the executing process. the MPU is optional and can be bypassed if not required by the application.

2.4. FLASH Accelerator (ACC)

In order to exploit the full performance of the processor, the accelerator will implement instruction prefetch queues and branch caching, thereby increasing the speed of program execution in Flash. According to CoreMark benchmark tests, the performance obtained by this accelerator needs to reach the equivalent of Flash executing programs in wait cycles at CPU frequencies up to 144 MHz.

- ICODE enables instruction prefetching
- Instruction cache of 64 branches with 128-bit data width
- Data cache of 16 branches with 128-bit data width

2.5. Boot mode

With the BOOT0 pin and BOOT1 pin, three different boot modes can be selected, as shown in the following table:

Table 2-1 Boot configuration

Boot mode configuration		Mode
BOOT1 Pin	BOOT0 pin	
X	0	Select Main flash as the boot area
0	1	Select System memory as boot area
1	1	Select SRAM as boot area

The boot loader program is stored in the System memory and is used to download the Flash program via the USART interface.

2.6. Backup register (BKP)

The backup registers are 42 16-bit registers that can be used to store 84 bytes of user application data. The modules are in the backup domain and when the V_{DD} power is cut, they are still maintained by V_{BAT} for power supply. They are also not reset when the system is woken up in standby mode, or when a system reset or power reset (POR) is performed.

- supports 84 bytes of data back-up registers
- Status/control register for managing anti-intrusion detection and with interrupt function
- Checksum register for storing RTC checksum values
- Outputs RTC calibration clock, RTC alarm pulses or second pulses on pin PC13 (when this pin is not used for intrusion detection)

2.7. Clock system

The default system clock frequency is HSI 8 MHz after the CPU has been booted, and the system clock frequency and system clock source can be reconfigured after the program has been run. The following high frequency clocks can be selected:

- an 8 MHz internal high precision HSI clock.
- A 40 kHz configurable internal LSI clock.
- a 4 ~ 32 MHz HSE clock, and the CSS function can be enabled to detect HSE. If CSS fails, the hardware automatically converts the system clock to HSI, the HSI frequency is configured by software, and the CPU NMI interrupt is generated.
- A 32.768 KHz LSE clock.
- PLL clock, PLL source can be selected as HSE. If HSE source is selected, when CSS is enabled and CSS fails, PLL and HSE are turned off and the hardware selects the system clock source as HSI.

The AHB clock can be divided based on the system clock and the APB clock can be divided based on the AHB clock. The AHB and APB clock frequencies are up to 144 MHz.

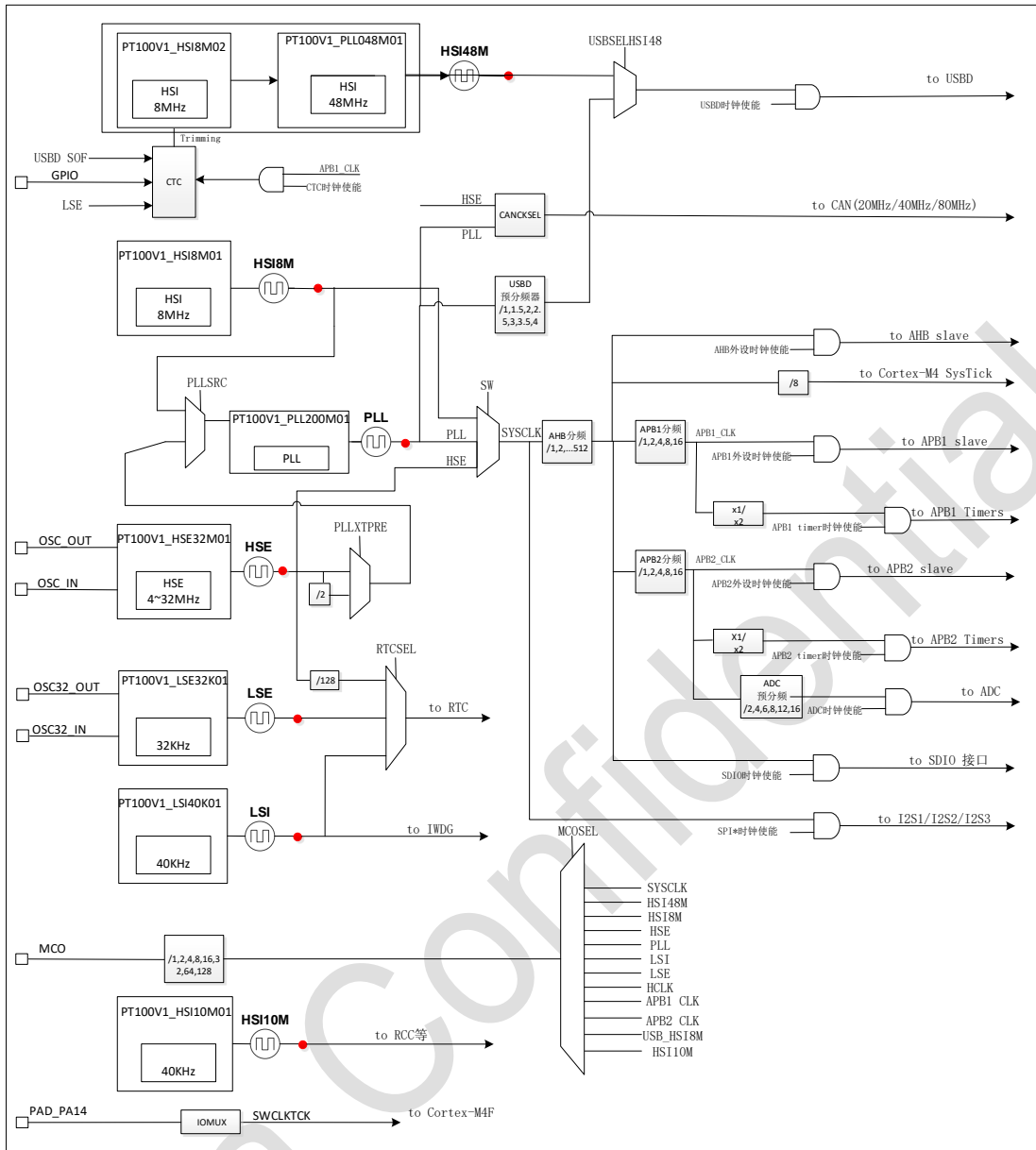

Figure 2-1 System clock structure diagram

2.8. Power Management

2.8.1. Power supply block diagram

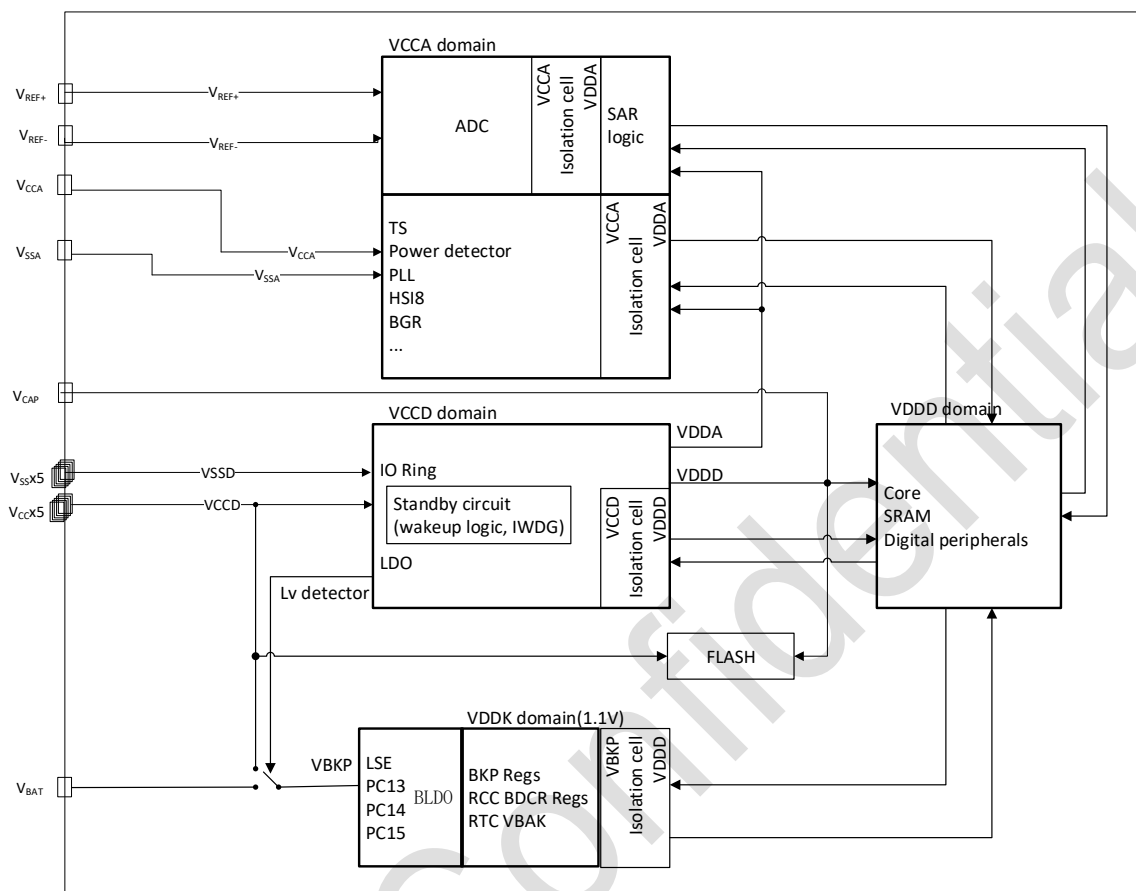

Figure 2-2 Power Block Diagram

Table 2-2 Power Block Diagram

No.	Power supply	Power value	Description
1	V _{CC}	1.8 V ~ 3.6 V	Power is supplied to the chip via the power pin.
2	V _{CAP} ⁽¹⁾	1.2 V/ 1.0 V ± 10%	The output from the VR supplies power to the main logic circuits and SRAM inside the chip. When MR is powered, the output is 1.2 V. When in stop mode, the output can be powered by MR or LPR, depending on the software configuration, and the LPR output is 1.2 V or 1.0 V, depending on the software configuration.
3	V _{CCA}	1.8 V ~ 3.6 V	The power supply pin provides power to the chip's analogue circuitry.

1. Stabilization for the main regulator is achieved by connecting an external capacitor C_{EXT} to the V_{CAP} pin. C_{EXT} and ESR is specified in the follow table :

Table 2-3 V_{CAP} operating conditions

Symbol	Parameters	Minimum	Maximum	Unit
C _{EXT}	Capacitance of external capacitor	0.1	1	μF
ESR	ESR of external capacitor	-	0.5	Ω

2.8.2. Power monitoring

2.8.2.1. Power on/power off reset (POR/PDR)

The Power On Reset (POR) / Power Down Reset (PDR) module is designed to provide a power up and power down reset for the chip. This module remains operational in all modes.

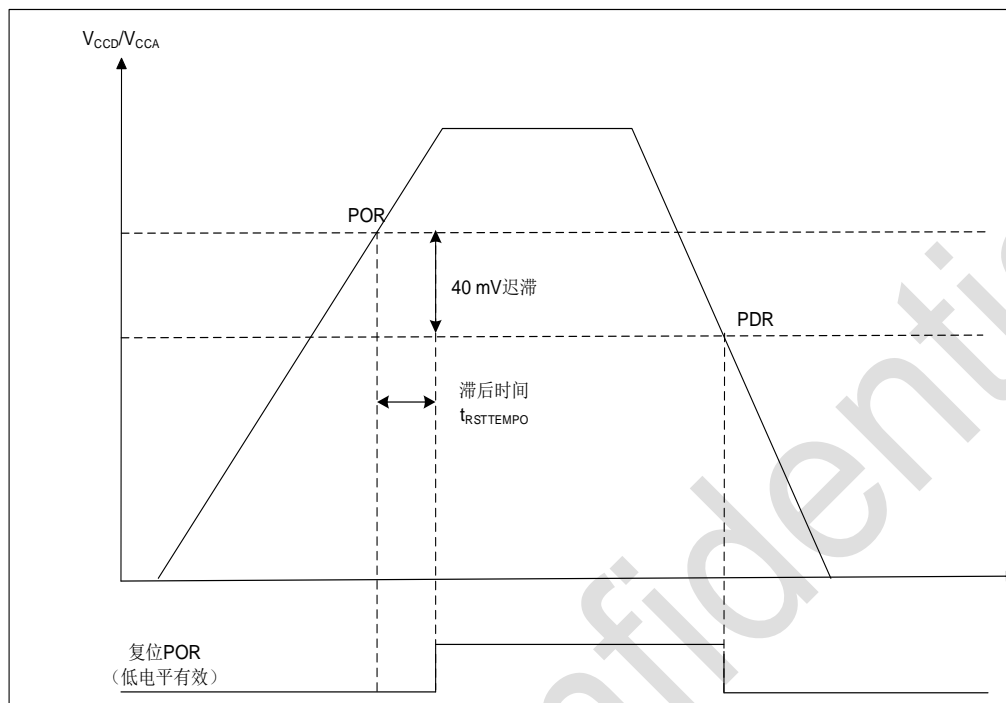

Figure 2-3 POR/PDR Threshold

2.8.2.2. Voltage detection (PVD)

The Programmable Voltage detector (PVD) module can be used to detect the V_{CC} supply, the detection point can be configured via a register. When V_{CC} is above or below the PVD detection point, a corresponding reset flag is generated.

The event is internally connected to EXTI line 16 and depending on the EXTI line 16 rising/falling edge configuration, an interrupt is generated when V_{CC} rises above the PVD detection point, or when V_{CC} falls below the PVD detection point.

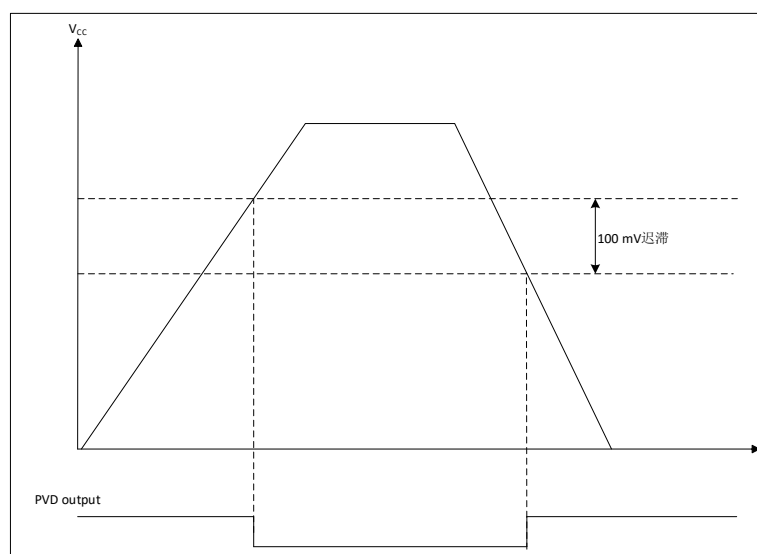

Figure 2-4 PVD Threshold

2.8.3. Voltage regulator

The chip is designed with three voltage regulators:

- The main mode MR (Main regulator) remains active during the normal operating state of the chip.
- Low power mode LPR (low power regulator) provides a lower power consumption option in the stop mode.
- Off mode for CPU standby mode. (LDO output high resistance, core power cut off, registers and SRAM contents lost)

2.8.4. Low power modes

The chip has 3 low power modes in addition to the normal operating modes:

- Sleep mode: CPU clock is switched off (NVIC, SysTick, etc. work), peripherals can be configured to keep working. (It is recommended to only enable modules that have to work and to switch off the module when it has finished working)
- Stop mode: In this mode the contents of SRAM and registers are held, the high speed clocks PLL, HSI and HSE are switched off and most of the module clocks in the V_{DD} domain are disabled. GPIO, PVD and RTC can be woken up in stop mode.
- Standby mode: The chip has a V_{BAT} power supply, so when V_{CC} is powered down, the chip only works in the V_{BKP} domain. There are four conditions for exiting from standby mode: external reset on NRST, IWDG reset, RTC alarm on time, rising edge on the WKUP pin.

2.9. Reset

Three types of reset are designed into the chip: power reset, system reset and backup domain reset.

2.9.1. Power Reset

The power reset is generated in the following situations:

- Power On / Power Off Reset (POR / PDR)

2.9.2. System Reset

A system reset is generated when the following events are generated:

- Reset of NRST pin
- Window Watchdog Reset (WWDG)
- Independent Watchdog Reset (IWDG)
- SYSRESETREQ software reset
- Option byte load reset (OBL)

2.10. General purpose input and output GPIOs

Each GPIO can be configured by software as an output (push - pull or open drain), input (floating, pull - up / down, analog), peripheral multiplexing function, and a locking mechanism that freezes the I/O port configuration function. The GPIO functions are summarized as follows:

- register supports IO Port / AHB bus read/write
- Output status: push-pull or open-drain + pull-up/down
- Data output from data registers (GPIOx_ODR) or peripherals (multiplexed function outputs)
- Speed selectable per I/O
- Input states: float, pull-up/pull-down, analog
- Data input to input data register (GPIOx_IDR) or peripheral (multiplexed function input)
- Position bit/reset register (GPIOx_BSRR), allows bit write access to GPIOx_ODR
- Locking mechanism (GPIOx_LCKR) will freeze the I/O port configuration function
- Analog functions
- Multiplexed function selection register (up to 16 multiplexed functions per IO port)
- Highly flexible I/O multiplexer function allows I/O ports to function as GPIOs, or as various peripheral interfaces

2.11. DMA

Direct Memory Access (DMA) is used to provide high-speed data transfer between peripherals and memory or between memory and memory. Moving data without CPU intervention, data can be moved quickly via DMA, which saves CPU resources for other operations. The device has two general purpose dual-port DMAs (DMA1 and DMA2) with seven and five channels respectively, each dedicated to managing requests for memory access from one or more peripherals. There is also an arbiter to coordinate the priority of individual DMA requests.

The main functions are as follows:

- single AHB master
- supports peripheral to memory, memory to peripheral, memory to memory and peripheral to peripheral data transfers
- On-chip memory devices such as FLASH, SRAM, AHB and APB peripherals, as source and destination
- All DMA channels can be configured independently:

- Each channel is either associated with a DMA request signal from a peripheral or with a software trigger in a memory-to-memory transfer. This configuration is done by software.
- The priority between requests is programmable by software (4 levels per channel: very high, high, medium, low) and in case of equality by hardware (e.g. requests for channel 1 have priority over requests for channel 2).
- The source and destination transfer sizes are independent (byte, half-word, word), simulating packetisation and unpacketisation. Source and destination addresses must be aligned by data size.
- Programmable number of data transfers: 0 to 65535
- Generates one interrupt request per channel. Each interrupt request is caused by any one of three DMA events: transfer complete, half-transfer or transfer error.

2.12. Interrupt

The PY32F403 handles exceptions via the Vector Interrupt Controller (NVIC) and an Extended Interrupt/Event Controller (EXTI) embedded in the Cortex-M4 processor.

2.12.1. Interrupt Controller NVIC

The NVIC is a tightly coupled IP inside the Cortex-M4 processor, which can handle NMI (non-maskable interrupts) and maskable external interrupts from outside the processor, as well as Cortex-M4 internal exceptions.

The tight coupling of the processor core to the NVIC greatly reduces the delay between interrupt events and the start of the corresponding interrupt service routines (ISRs), which are listed in a vector table and stored at a base address in the NVIC. The vector address of the ISR to be executed is made up of the vector table base address and the ISR sequence number used as an offset.

If a high priority interrupt event occurs and a low priority interrupt event is waiting for a response, the higher priority interrupt event that arrives later will be responded to first. Another type of optimisation is called tail-chaining. When returning from a high-priority ISR, a pending low-priority ISR is then started, skipping unnecessary processor context stacking and stack popping. This reduces latency and improves power efficiency.

NVIC features:

- Low latency interrupt handling
- 4 levels of interrupt priority
- 1 NMI interrupt support
- 60 maskable interrupt channels (not including 16 CPU interrupts)
- High-priority interrupts can interrupt low-priority interrupt responses
- support for tail - chaining optimization
- Hardware interrupt vector retrieval

2.12.2. Extended Interrupt EXTI

- EXTI adds flexibility in handling physical line events, as the system can be woken up by GPIO and specified module (PVD/RTC) input events.

- The EXTI controller has multiple channels, including up to 16 GPIOs, one PVD output and RTC wake-up signals. The GPIO, PVD can be configured for rising edge, falling edge or double edge triggering. Any GPIO signal is configured as EXTI0 ~ 15 channels by means of a selection signal.
- Each EXTI line can be masked independently via registers.
- The EXTI controller can capture pulses shorter than the internal clock period.
- Registers in the EXTI controller latch each event, even in stop mode, so that the processor can identify the source of the wake-up call after waking up from stop mode, or identify the GPIO and event that caused the interrupt.

2.13. Analog-to-digital converter ADCs

- The module has a total of up to 19 channels to be measured, including 16 external channels and 3 internal channels, and performs conversions in single or sweep mode.
- The conversion mode for each channel can be set to single, continuous, scan or discontinuous mode. The conversion results are stored in a left- or right-aligned 16-bit data register.
- The analogue watchdog allows the application to detect if the input voltage exceeds a user defined high or low threshold.
- The ADC enables operation at low frequencies, resulting in very low power consumption. Interrupt requests are generated at the end of sampling, at the end of conversion, at the end of continuous conversion, and when the conversion voltage exceeds the threshold at analog watchdog.

2.14. Timer

The characteristics of the different timers of the PY32F403 are shown in the following table:

Table 2-4 Timer features

Type	Timer	Bit width	Counting direction	Prescaler	DMA	Capture/compare channel	Complementary output
Advanced Timer	TIM1	16 bits	Top, bottom, center alignment	1 ~ 65536	Support	4	3
	TIM8	16 bits	Top, Bottom, Centre Aligned	1 ~ 65536	Support	4	3
General Purpose Timer	TIM2	16 bits	Top, Bottom, Centre Aligned Alignment	1 ~ 65536	Support	4	-
	TIM3	16 bits	Top, Bottom, Centre Aligned Alignment	1 ~ 65536	Support	4	-
	TIM4	16 bits	Top, Bottom, Central Alignment	1 ~ 65536	Support	4	-
	TIM5	16 bits	Top, Bottom, Centre Align	1 ~ 65536	Support	4	-
General purpose timer	TIM10/ TIM11/ TIM13/ TIM14	16 bits	top	1 ~ 65536	-	1	-
General purpose timer	TIM9/ TIM12	16 bits	top	1 ~ 65536	-	2	-
Basic Timer	TIM6,TIM7	16 bits	top	1 ~ 65536	-	-	-

2.14.1. Advanced Timer

The advanced timer (TIM1/TIM8) consists of a 16-bit auto-load counter driven by a programmable

divider. It can be used in various scenarios, including: pulse length measurement of the input signal (input capture) or to generate output waveforms (output comparison, output PWM, complementary PWM with deadband insertion).

TIM1/TIM8 include 4 independent channels used as

- input capture
- output compare
- PWM generation (edge or center aligned mode)
- single pulse mode output

If the TIM1/TIM8 is configured as a standard 16-bit timer, it has the same characteristics as the TIMx timer. If configured as a 16-bit PWM generator, it has full modulation capability (0 - 100%).

In MCU debug mode, TIM1/TIM8 can freeze the count.

The timer features with the same architecture are shared so that TIM1/TIM8 can work together with other timers via the timer link function for synchronisation or event linking.

TIM1/TIM8 support the DMA function.

2.14.2. General purpose timers

2.14.2.1. TIM2/TIM3/TIM4/TIM5

The TIM2/TIM3/TIM4/TIM5 general purpose timers consist of a 16-bit automatic reload counter driven by a 16-bit programmable divider. There are four independent channels, each for input capture/output comparison, PWM or single pulse mode output.

- can work with TIM1 via the timer link function
- supports DMA functions
- Capable of handling quadrature (incremental) encoder signals and digital outputs from 1 to 3 Hall effect sensors
- In MCU debug mode, TIM2/TIM3/TIM4/TIM5 can freeze the count

2.14.2.2. TIM10/ TIM11/ TIM13/TIM14

- The general purpose timer TIM10/TIM11/TIM13/TIM14 consists of a 16-bit upward auto-loading counter driven by a programmable prescaler.
- TIM10/TIM11/TIM13/TIM14 have 1 independent channel for input capture/output comparison, PWM or single pulse mode output.
- In MCU debug mode, TIM10/TIM11/TIM13/TIM14 can freeze the count.

2.14.2.3. TIM9/TIM12

- TIM9 and TIM12 consist of 16-bit upward auto-loading counters driven by programmable prescalers.
- TIM9 and TIM12 have 2 independent channels for input capture/output comparison, PWM or single pulse mode output.
- TIM9 and TIM12 have complementary outputs with deadband.
- In MCU debug mode, TIM9 and TIM12 can freeze the count.

2.14.3. Basic Timer TIM6/TIM7

- The basic timers TIM6/TIM7 contain a 16-bit auto-load counter driven by the respective programmable prescaler.
- 16-bit auto load counter.
- Generates an interrupt/DMA request on the occurrence of an update event (counter overflow).

2.14.4. IWDG

An Independent watchdog (IWDG) is integrated into the chip, which is characterized by a high level of security, timing accuracy and flexibility. IWDG detects and resolves functional disruptions due to software failures and triggers a system reset when the counter reaches a specified timeout value.

- The IWDG is clocked by a separate RC oscillator and can be operated in STOP and STANDBY modes.
- The IWDG is best suited for applications that require a watchdog as a separate process from the main application and do not have high timing accuracy constraints.
- The IWDG hardware mode can be enabled by option byte control.
- IWDG is the wakeup source for the stop mode and wakes up the stop mode with a reset.
- In MCU debug mode, IWDG can freeze the count value.

2.14.5. WWDG

The system window watchdog is based on a 7-bit downstream counter and can be set to free run. It can be used as a watchdog to reset the system in case of a problem. The counter clock is the APB clock (PCLK). It has a warning interrupt capability and the counter can be frozen in MCU debug mode.

2.14.6. SysTick timer

SysTick counters are designed for use with Real Time Operating Systems (RTOS), but can also be used as standard down counters.

SysTick features:

- 24-bit down counter
- Self-loading capability
- Interrupts can be generated when the counter reaches 0 (maskable)

2.15. Real Time Clock RTC

The Real Time Clock is a stand-alone timer, the RTC module has a set of continuous counters which, when configured with the appropriate software, provide the function of a clock calendar. Modifying the counter values resets the current time and date of the system.

- The RTC is a 32-bit programmable counter with a prescale factor of up to 2^{20} .
- The RTC counter clock source can be the LSE, LSI and HSE clock divided by 128 and can be used as a stop wake-up source.
- The RTC can generate alarm interrupts, second interrupts and overflow interrupts (maskable).
- RTC supports clock calibration.
- In MCU debug mode, the RTC can freeze the count.

2.16. Cyclic Redundancy Check Calculation Unit CRC

The cyclic redundancy checks (CRC) calculation unit is a 32-bit CRC calculation based on a fixed generating polynomial. Among other applications, CRC technology is used to verify the correctness and integrity of data transmission or data storage. The CRC calculation unit contains a 32-bit data register:

- A write operation to this register serves as an input register for entering new data for the CRC calculation.
- A read of this register returns the result of the last CRC calculation.
- Each time a data register is written, the result of the calculation is a combination of the previous CRC calculation and the new calculation (CRC calculation is performed on the entire 32-bit word rather than byte by byte).
- can reset the register CRC_DR to 0xFFFF FFFF by setting the RESET bit of the register CRC_CR. This operation does not affect the data in the register CRC_IDR.
- supports the configuration of the initial CRC value.

2.17. Clock Calibration System CTC

The Clock Calibration Controller (CTC) uses hardware to automatically calibrate the internal RC crystal configured at 48 MHz and used as the clock source for the USB module. The CTC module calibrates the HSI clock frequency based on an external high precision reference source and adjusts the calibration value automatically or manually to obtain an accurate PLL48M clock.

The CTC module performs the following functions:

- Three external reference sources: GPIO, LSE clock, USBD_SOF.
- provides software reference synchronisation pulses.
- Hardware auto-calibration, no software required.
- 16-bit calibration counter with reference signal source capture and reload function.
- 8-bit clock calibration base for frequency evaluation and automatic calibration.
- Flag bits and interrupts to indicate the status of the clock calibration: calibration success (CKOKIF), warning status (CKWARNIF) and error status (ERRIF).

2.18. System Configuration Controller SYSCFG

The SYSCFG module performs the following functions:

- I²C fast mode plus, enabling/disabling some IO ports.
- Mapping of the initial program area according to the different boot modes.
- DMA peripheral channel selection control.
- TIMx cascade control.

2.19. Debug support (DBG)

The MCU DBG module assists the debugger by providing the following features:

- supports sleep mode, stop mode and standby mode
- Timer and watchdog stop counting or continue counting when CPU enters HALT

- CPU enters HALT to prevent I2C1 and I2C2 SMBUS timeout
- Prevent CANFD receive register update when CPU enters HALT
- Assign trace pins

The MCUIDBG register also provides the chip ID code. This ID code can be accessed using the JTAG or SW debug interface, or by the user program.

2.20. SDIO

The SD/SDIO MMC card host module (SDIO) provides an operational interface between the AHB peripheral bus and multimedia cards (MMC), SD memory cards, SDIO cards and CE-ATA devices.

The following functions are supported:

- Support for SD card version 2.0
- Support for SD I/O cards version 2.0
- supports MMC version 4.2
- Support for CE-ATA version 1.1
- Support for command completion signals and interrupts to the host processor
- Command completion signal off function

SDIO does not support SPI mode communication mode, only I/O mode for the I/O portion of the SD card or composite card, and cannot support many commands in SD memory devices, such as the erase command. In addition, some commands in SD memory cards and SD I/O cards are different, and SDIO does not support these commands.

2.21. I²C interface

The I²C (inter-integrated circuit) bus interface connects the microcontroller to the serial I²C bus. It provides multi-host functionality and controls all I²C bus specific sequences, protocols, arbitration and timing. Standard (Sm) and Fast (FM) are supported.

I²C features:

- 2 I²C interfaces, supports Slave and Master modes
- Multi-host function: master and slave
- Support for different communication speeds
 - Standard mode (Sm): up to 100 kHz
 - Fast mode (FM): up to 400 kHz
- as master
 - Clock generation
 - Start and Stop generation
- as slave
 - Programmable I2C address detection
 - Dual address capability to respond to 2 slave addresses
 - Stop bit discovery
- 7-bit/10-bit addressing mode
- General broadcast (General call)
- Status flag bit

- Transmit/receive mode flag bit
- Byte transfer complete flag bit
- I²C busy flag bit
- Error flag bit
 - Master arbitration loss
 - ACK failure after address/data transfer
 - Start/Stop error
 - Overrun/Underrun (clock stretching function disable)
- Optional clock stretching function
- DMA-capable single-byte buffer
- Software reset
- Analogue noise filtering function
- SMBus support

2.22. Universal Synchronous Asynchronous Transceiver USART

The PY32F403 contains 5 Universal Synchronous/Asynchronous Transceivers (USART), supporting ISO7816, LIN, IrDA.

The Universal Synchronous Asynchronous Transceiver (USART) provides a flexible method of exchanging full duplex data with external devices using the industry standard NRZ asynchronous serial data format. USART provides a wide range of baud rate options using a fractional baud rate generator. It supports synchronous unidirectional communication and half-duplex single-line communication, and it also allows multi-processor communication.

Automatic baud rate detection is supported.

High speed data communication is possible using the DMA method with multi-buffer configuration.

USART features:

- Full duplex asynchronous communication
- NRZ standard format
- Configurable with 16x or 8x oversampling for increased flexibility in speed and clock tolerance
- Shared programmable baud rate for transmit and receive, up to 4.5 Mbit/s
- Automatic baud rate detection
- Programmable data length of 8 or 9 bits
- Configurable stop bits (0.5, 1, 1.5 or 2 stop bits supported)
- Transmitter provides clock for synchronous transmission
- Single-wire half-duplex communication
- Separate transmit and receive enable bits
- Hardware flow control
- Receive/send bytes buffered via DMA
- Detect flag
 - Receive buffer full
 - Send buffer empty

- End of transfer
- Parity control
 - Send parity bit
 - Check summing of received data
- Interrupt source with flags
 - CTS change
 - Send register empty
 - Send complete
 - Receive data register full
 - Bus idle detected
 - Overflow error
 - Frame error
 - Noise operation
 - Checksum error
 - LIN disconnecter detection
- Multiprocessor communication
 - Silent mode if address does not match
- Wake up from silent mode: two ways of waking up the receiver by idle detection and address flag detection: address bit (MSB, bit 9), bus idle.

2.23. Serial Peripheral Interface SPI

The PY32F403 contains three SPI's. The Serial Peripheral Interface (SPI) allows the chip to communicate with external devices in half duplex, full duplex and simplex synchronous serial mode. The interface can be configured in master mode and provides a communication clock (SCK) for external slave devices. The interface can also operate in a multi-master configuration.

The SPI features are as follows:

- Master or slave mode
- 3-wire full duplex synchronous transmission
- 2-wire half-duplex synchronous transmission (with bi-directional data lines)
- 2-wire simplex synchronous transmission (no bidirectional data lines)
- 8-bit or 16-bit transmission frame selection
- Multi-master mode support
- 8 master mode baud rate prescale factors (max. $f_{PCLK}/4$)
- Slave mode frequency (up to $f_{PCLK}/4$)
- NSS management by software or hardware in both master and slave modes: dynamic change of master/slave operation mode
- Programmable clock polarity and phase
- Programmable data order, MSB first or LSB first
- Dedicated transmit and receive flags that can trigger interrupts
- SPI bus busy status flags

- Motorola mode
- Master mode faults, overloads that can cause interrupts
- 2 DMA-capable 32-bit Rx and Tx FIFOs

2.24. Internal integrated audio (I2S)

- 2 I2S bus interfaces with sampling rates from 8 KHz to 192 KHz
- Supports master and slave modes, full duplex and simplex communication modes

The I2S bus provides a standard communication interface for digital audio applications over a 3-wire serial line. Contains two I2S bus interfaces that can operate in master or slave mode at 16/32-bit resolution, with pins multiplexed with SPI1 and SPI2 Audio sampling frequencies from 8 KHz to 192 KHz are supported with an accuracy error of less than 0.5%. All I2S interfaces can be used with a DMA controller.

2.25. External Serial Memory Controller (ESMC)

The ESMC (External Serial Memory Controller) is a dedicated communication interface for single (Single SPI), dual (Dual SPI), quad (Quad SPI) and octal (Octal SPI) channel SPI interface memories (NOR Flash, PSRAM, etc.). It can operate in either of the following two modes:

- Indirect mode: all operations are performed using the QUADSPI registers (indirect mode)
- memory mapped mode: the external flash is mapped to the device address space and the system treats it as internal memory (memory mapped mode)

Using dual memory mode, i.e. accessing two Quad SPI memories at the same time, can achieve twice the throughput and storage capacity similar to the Octal SPI memory.

- Two functional modes: indirect and memory mapped
- Simultaneous transmit/receive of 8 bits
- Dual Flash mode with simultaneous send/receive of 8 bits by accessing two Flash memories in parallel
- Octal SPI
- SDR and DDR support
- Fully programmable opcodes for indirect and memory mapped modes
- Fully programmable frame format for indirect and memory mapped modes
- Integrated FIFO for receive and transmit
- Allows 8-, 16- and 32-bit data access
- DMA channel for indirect mode operation
- Interrupt generation on completion of FIFO operations

2.26. USB 2.0 Full Speed Module

The PY32F403 contains a USB 2.0 Full Speed module, a USB peripheral that interfaces between the USB 2.0 Full Speed bus and the APB1 bus. It supports USB suspend/resume operation and can stop the device clock to achieve low power consumption. Key features are as follows:

- Conforms to the USB 2.0 Full Speed Device specification
- Configurable from 1 to 8 USB endpoints

- CRC (cyclic redundancy check) generation/checking, reverse non-zero (NRZI) encoding/decoding and bit padding
- Support for simultaneous transfers
- Dual buffer mechanism with support for bulk/synchronous endpoints
- Support for USB suspend/resume operations
- frame-locked clock pulse generation

2.27. CANFD

The PY32F403 contains a CANFD communication interface module.

The CAN (Controller Area Network) bus is a bus standard that enables microprocessors or devices to communicate with each other without a host. the CAN FD controller follows the CAN bus CAN 2.0 (2.0A, CAN 2.0B) and the CAN FD protocol.

The CAN bus controller can handle the sending and receiving of data on the bus. In this product, the CAN FD controller has 12 groups of filters. The filters are used to select the messages to be received for the application.

The application in the CAN FD controller can send transmit data to the bus via one high-priority Primary Transmit Buffer (hereinafter referred to as PTB) and three Secondary Transmit Buffers (hereinafter referred to as STB), with the transmit scheduler determining the order in which mailboxes are sent. The three STBs and the three RBs can be understood as a 3-stage FIFO and a 3-stage FIFO, which are fully controlled by the hardware.

The CAN FD bus controller can also support time-trigger communication.

- fully supports CAN2.0A/ CAN2.0B/ CANFD protocols
- CAN2.0 supports a maximum communication baud rate of 1 Mbit/s
- Supports prescaling of baud rates from 1 to 1/ 32 for flexible baud rate configuration
- 3 receive buffers
 - FIFO method
 - Errors or non-received data do not overwrite stored messages
- 1 high priority primary transmit buffer PTB
- 3 sub-send buffers STB
 - FIFO method
 - Priority arbitration method
- 12 independent filter groups
 - Supports 11-bit standard ID and 29-bit extended ID
 - Programmable ID CODE bits and MASK bits
- PTB/STB both support single send mode
- Silent mode support
- Supports loopback mode
- Support for capturing the type of error transmitted and locating the location of the arbitration failure
- Programmable error warning values
- Support for ISO 11898 - 4 time triggered CANFD and receive timestamps

2.28. SWD

The ARM SWD interface allows serial debugging tools to be connected to the PY32F403.

Puya Confidential

3. Pin Configuration

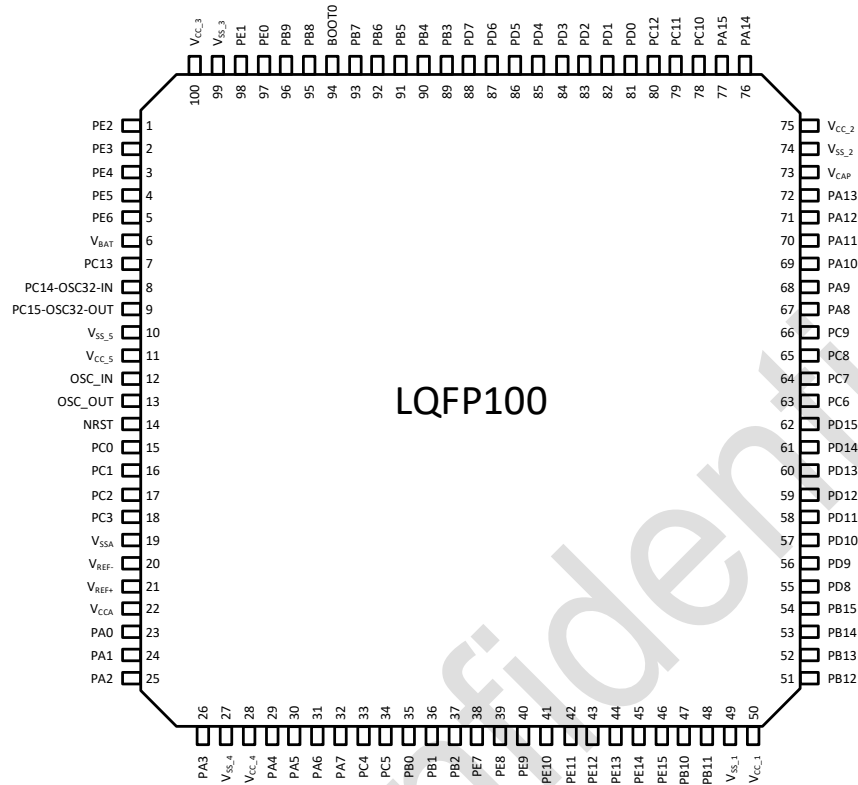

Figure 3-1 LQFP100 PY32F403V1xT Pinout1

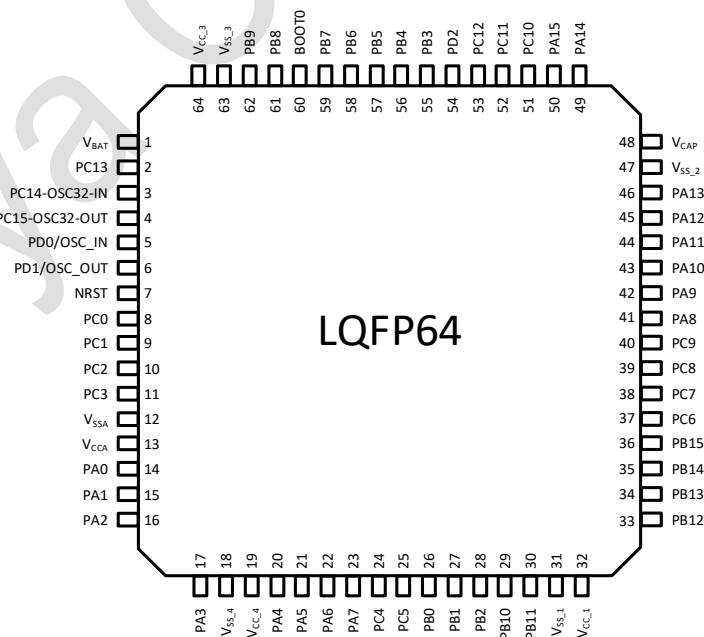

Figure 3-2 LQFP64 PY32F403R1xT Pinout1

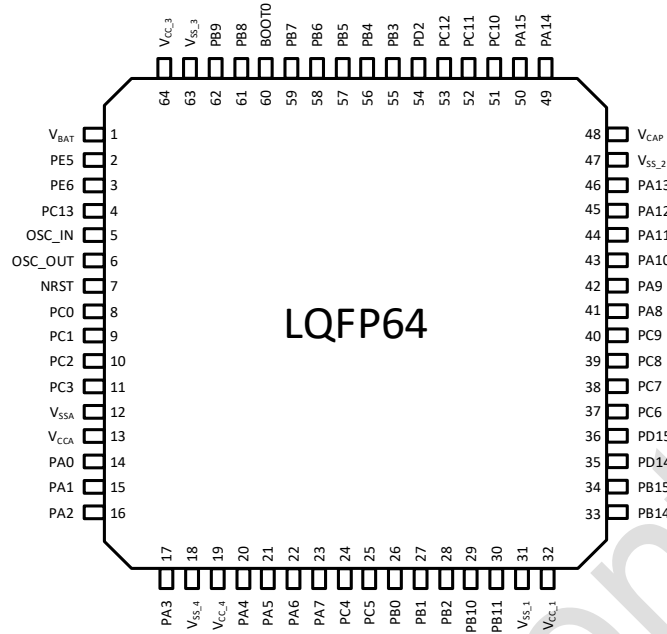

Figure 3-3 LQFP64 PY32F403R2xT Pinout2

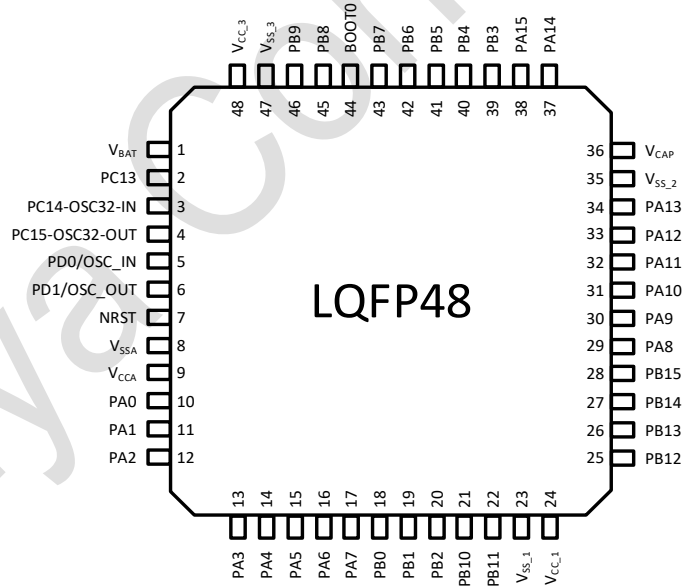

Figure 3-4 LQFP48 PY32F403C1xT Pinout1

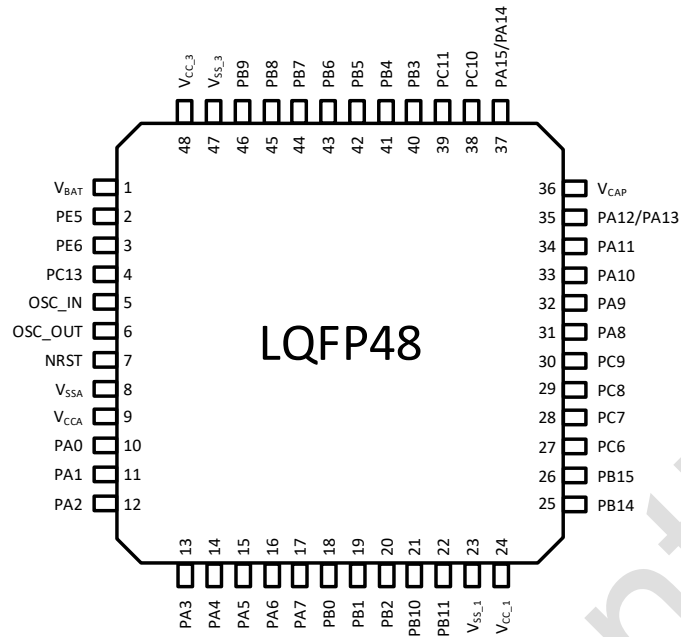

Figure 3-5 LQFP48 PY32F403C2xT Pinout2

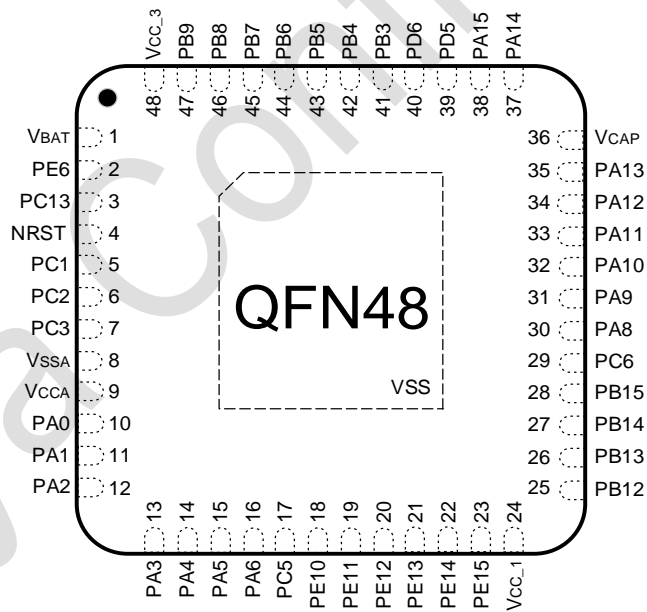

Figure 3-6 QFN48 PY32F403C1xU Pinout1

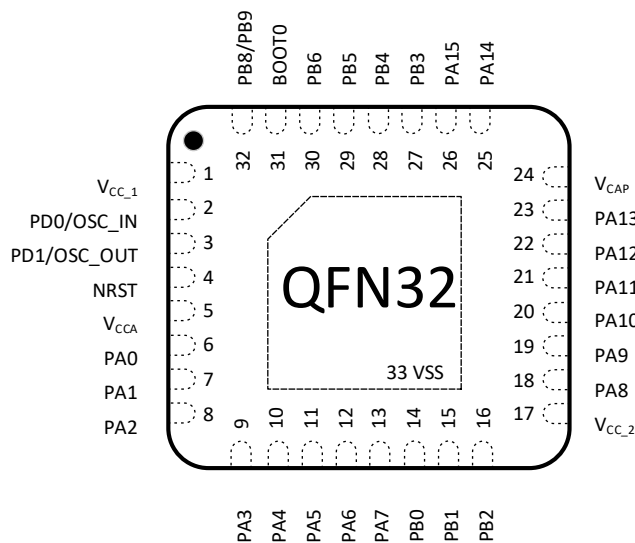

Figure 3-7 QFN32 PY32F403K1xU Pinout1

Table 3-1 Terminology and symbols for pin definitions

Type	Symbol	Definition	
Port Type	S	Supply pin	
	G	Ground pin	
	I	Input - only pin	
	I/O	Input/ output pin	
	NC	No definition	
Port Structure	FT	Normal 5 V port, supports analogue input and output functions	
	RST	Reset port with internal weak pull-up resistor, no analog input/output support	
Notes	-	Unless otherwise stated, all ports are used as floating inputs between and after resets	
10	Multiplexed function	-	Functions selected via the GPIOx_AFR register
	Additional Function	-	Functions directly selected or enabled via peripheral registers

Table 3-2 Pin definitions

Package Type							Reset	Ports Type	Ports structure	Reset function ⁽¹⁾	Port Function	
LQFP100 V1	LQFP64 R1	LQFP64 R2	LQFP48 C1	LQFP48 C2	QFN48 C1	QFN32 K1					Multiplexed function	Additional function
1	-	-	-	-	-	-	PE2	I/O	FT	PE2	TRACECK EVENT_OUT	-
2	-	-	-	-	-	-	PE3	I/O	FT	PE3	TRACED0 EVENT_OUT	-
3	-	-	-	-	-	-	PE4	I/O	FT	PE4	TRACED1	-

Package Type							Reset	Ports Type	Ports structure	Reset function ⁽¹⁾	Port Function	
LQFP100 V1	LQFP64 R1	LQFP64 R2	LQFP48 C1	LQFP48 C2	QFN48 C1	QFN32 K1					Multiplexed function	Additional function
											EVENT_OUT	
4	-	2	-	2	-	-	PE5	I/O	FT	PE5	TRACED2	-
											TIM9_CH1	
											EVENT_OUT	
5	-	3	-	3	2	-	PE6	I/O	FT	PE6	TRACED3	WKUP3
											TIM9_CH2	
											ENENT_OUT	
6	1	1	1	1	1	-	V _{BAT}	S	-	V _{BAT}	-	-
7	2	4	2	4	3	-	PC13-TAMPER RTC ^{(2) (3)}	I/O	-	PC13	EVENT_OUT	TAMPER-RTC WKUP2
8	3	-	3	-	-	-	PC14-OSC32_IN ^{(2) (3)}	I/O	-	PC14	EVENT_OUT	OSC32_IN
9	4	-	4	-	-	-	PC15-OSC32_OUT ⁽²⁾	I/O	-	PC15	EVENT_OUT	OSC32_OUT
10	-	-	-	-	-	-	V _{SS_5}	S	-	V _{SS_5}	-	-
11	-	-	-	-	-	-	V _{CC_5}	S	-	V _{CC_5}	-	-
12	5	5	5	5	-	2	OSC_IN	I	-	OSC_IN	-	-
13	6	6	6	6	-	3	OSC_OUT	O	-	OSC_OUT	-	-
14	7	7	7	7	4	4	NRST	I/O	-	NRST	-	-
15	8	8	-	-	-	-	PC0	I/O	-	PC0	EVENT_OUT	ADC123_IN10
16	9	9	-	-	5	-	PC1	I/O	-	PC1	ESMC_IO4	ADC123_IN11
											EVENT_OUT	
17	10	10	-	-	6	-	PC2	I/O	-	PC2	ESMC_IO5	ADC123_IN12
											EVENT_OUT	
18	11	11	-	-	7	-	PC3	I/O	-	PC3	ESMC_IO6	ADC123_IN13
											EVENT_OUT	
19	12	12	8	8	8	-	V _{SSA}	S	-	V _{SSA}	-	-
20	-	-	-	-	-	-	V _{REF-}	S	-	V _{REF-}	-	-
21	-	-	-	-	-	-	V _{REF+}	S	-	V _{REF+}	-	-
22	13	13	9	9	9	5	V _{CCA}	S	-	V _{CCA}	-	-
23	14	14	10	10	10	6	PA0-WKUP1	I/O	-	PA0	WKUP1	ADC123_IN0 WKUP1
											USART2_CTS	
											TIM8_ETR	
											TIM2_CH1_ETR	
											TIM5_CH1	
											EVENT_OUT	
24	15	15	11	11	11	7	PA1	I/O	-	PA1	USART2_RTS	ADC123_IN1
											TIM2_CH2	
											TIM5_CH2	
											EVENT_OUT	
25	16	16	12	12	12	8	PA2	I/O	-	PA2	USART2_TX	ADC123_IN2 WKUP4
											TIM2_CH3	
											TIM5_CH3	
											TIM9_CH1	
											ESMC_SS0	

Package Type							Reset	Ports Type	Ports structure	Reset function (1)	Port Function	
LQFP100 V1	LQFP64 R1	LQFP64 R2	LQFP48 C1	LQFP48 C2	QFN48 C1	QFN32 K1					Multiplexed function	Additional function
											EVENT_OUT	
26	17	17	13	13	13	9	PA3	I/O	-	PA3	USART2_RX	ADC123_IN3
											TIM2_CH4	
											TIM5_CH4	
											TIM9_CH2	
											ESMC_CLK	
											EVENT_OUT	
27	18	18	-	-	-	-	V _{SS_4}	S	-	V _{SS_4}	-	-
28	19	19	-	-	-	-	V _{CC_4}	S	-	V _{CC_4}	-	-
29	20	20	14	14	14	10	PA4	I/O	-	PA4	USART2_CK	ADC12_IN4
											SPI1_NSS	
											EVENT_OUT	
30	21	21	15	15	15	11	PA5	I/O	-	PA5	SPI1_SCK	ADC12_IN5
											EVENT_OUT	
31	22	22	16	16	16	12	PA6	I/O	-	PA6	SPI1_MISO	ADC12_IN6
											TIM8_BKIN	
											TIM3_CH1	
											TIM13_CH1	
											ESMC_IO3	
											EVENT_OUT	
32	23	23	17	17	-	13	PA7	I/O	-	PA7	SPI1_MOSI	ADC12_IN7
											TIM8_CH1N	
											TIM14_CH1	
											ESMC_IO2	
33	24	24	-	-	-	-	PC4	I/O	-	PC4	ESMC_IO7	ADC12_IN14
											EVENT_OUT	
34	25	25	-	-	17	-	PC5	I/O	-	PC5	EVENT_OUT	ADC12_IN15 WKUP5
35	26	26	18	18	-	14	PB0	I/O	-	PB0	TIM1_CH2N	ADC12_IN8
											TIM8_CH2N	
											TIM3_CH3	
											ESMC_IO1	
											I ² S3_CK	
EVENT_OUT												
36	27	27	19	19	-	15	PB1	I/O	-	PB1	TIM1_CH3N	ADC12_IN9
											TIM8_CH3N	
											ESMC_IO0	
											EVENT_OUT	
37	28	28	20	20	-	16	PB2	I/O	FT	PB2/BOOT1	EVENT_OUT	BOOT1
38	-	-	-	-	-	-	PE7	I/O	FT	PE7	TIM1_ETR	-
39	-	-	-	-	-	-	PE8	I/O	FT	PE8	TIM1_CH1N	-
40	-	-	-	-	-	-	PE9	I/O	FT	PE9	TIM1_CH1	-
41	-	-	-	-	18	-	PE10	I/O	FT	PE10	TIM1_CH2N	-
											ESMC_CLK	

Package Type							Reset	Ports Type	Ports structure	Reset function ⁽¹⁾	Port Function	
LQFP100 V1	LQFP64 R1	LQFP64 R2	LQFP48 C1	LQFP48 C2	QFN48 C1	QFN32 K1					Multiplexed function	Additional function
											EVENT_OUT	
42	-	-	-	-	19	-	PE11	I/O	FT	PE11	TIM1_CH2	-
											ESMC_SS3	
											EVENT_OUT	
43	-	-	-	-	20	-	PE12	I/O	FT	PE12	TIM1_CH3N	-
											ESMC_IO0	
											EVENT_OUT	
44	-	-	-	-	21	-	PE13	I/O	FT	PE13	TIM1_CH3	-
											ESMC_IO1	
											EVENT_OUT	
45	-	-	-	-	22	-	PE14	I/O	FT	PE14	TIM1_CH4	-
											ESMC_IO2	
											EVENT_OUT	
46	-	-	-	-	23	-	PE15	I/O	FT	PE15	TIM1_BKIN	-
											ESMC_IO3	
											EVENT_OUT	
47	29	29	21	21	-	-	PB10	I/O	FT	PB10	I ² C2_SCL	-
											USART3_TX	
											TIM2_CH3	
											ESMC_CLK	
											EVENT_OUT	
48	30	30	22	22	-	-	PB11	I/O	FT	PB11	I ² C2_SDA	-
											USART3_RX	
											TIM2_CH4	
											ESMC_SS1	
49	31	31	23	23	-	-	V _{SS_1}	S	-	V _{SS_1}	-	-
50	32	32	24	24	24	1	V _{CC_1}	S	-	V _{CC_1}	-	-
51	33	-	25	-	25	-	PB12	I/O	FT	PB12	I ² C2_SMBA	-
											USART3_CK	
											SPI2_NSS	
											TIM1_BKIN	
											I ² S2_WS	
											EVENT_OUT	
52	34	-	26	-	26	-	PB13	I/O	FT	PB13	USART3_CTS	-
											SPI2_SCK	
											TIM1_CH1N	
											I ² S2_CK	
											EVENT_OUT	
53	35	33	27	25	27	-	PB14	I/O	FT	PB14	USART3_RTS	-
											SPI2_MISO	
											TIM1_CH2N	
											TIM12_CH1	
											EVENT_OUT	
54	36	34	28	26	28	-	PB15	I/O	FT	PB15	SPI2_MOSI	-

Package Type							Reset	Ports Type	Ports structure	Reset function ⁽¹⁾	Port Function	
LQFP100 V1	LQFP64 R1	LQFP64 R2	LQFP48 C1	LQFP48 C2	QFN48 C1	QFN32 K1					Multiplexed function	Additional function
											TIM1_CH3N	
											TIM12_CH2	
											I ² S2_SD	
											EVENT_OUT	
55	-	-	-	-	-	-	PD8	I/O	FT	PD8	USART3_TX	-
											EVENT_OUT	
56	-	-	-	-	-	-	PD9	I/O	FT	PD9	USART3_RX	-
											EVENT_OUT	
57	-	-	-	-	-	-	PD10	I/O	FT	PD10	USART3_CK	-
											EVENT_OUT	
58	-	-	-	-	-	-	PD11	I/O	FT	PD11	USART3_CTS	-
											EVENT_OUT	
59	-	-	-	-	-	-	PD12	I/O	FT	PD12	TIM4_CH1	-
											USART3_RTS	
											EVENT_OUT	
60	-	-	-	-	-	-	PD13	I/O	FT	PD13	TIM4_CH2	-
											EVENT_OUT	
61	-	35	-	-	-	-	PD14	I/O	FT	PD14	TIM4_CH3	-
											EVENT_OUT	
62	-	36	-	-	-	-	PD15	I/O	FT	PD15	TIM4_CH4	-
											EVENT_OUT	
63	37	37	-	27	29	-	PC6	I/O	FT	PC6	USART4_CK	-
											TIM8_CH1	
											TIM3_CH1	
											SDIO_D6	
											I ² S2_MCK	
											EVENT_OUT	
64	38	38	-	28	-	-	PC7	I/O	FT	PC7	USART4_CTS	-
											TIM8_CH2	
											TIM3_CH2	
											SDIO_D7	
											I ² S3_MCK	
											EVENT_OUT	
65	39	39	-	29	-	-	PC8	I/O	FT	PC8	USART4_RTS	-
											TIM8_CH3	
											TIM3_CH3	
											SDIO_D0	
											EVENT_OUT	
66	40	40	-	30	-	-	PC9	I/O	FT	PC9	TIM8_CH4	-
											TIM3_CH4	
											SDIO_D1	
											EVENT_OUT	
67	41	41	29	31	30	18	PA8	I/O	FT	PA8	MCO	-
											USART1_CK	
											TIM1_CH1	

Package Type							Reset	Ports Type	Ports structure	Reset function (1)	Port Function	
LQFP100 V1	LQFP64 R1	LQFP64 R2	LQFP48 C1	LQFP48 C2	QFN48 C1	QFN32 K1					Multiplexed function	Additional function
											EVENT_OUT	
68	42	42	30	32	31	19	PA9	I/O	FT	PA9	USART1_TX TIM1_CH2	-
											EVENT_OUT	
69	43	43	31	33	32	20	PA10	I/O	FT	PA10	USART1_RX CTC_SYNC TIM1_CH3	-
											EVENT_OUT	
70	44	44	32	34	33	21	PA11	I/O	FT	PA11	USART1_CTS TIM1_CH4 CAN_RX	USB_DM
											EVENT_OUT	
71	45	45	33	35	34	22	PA12	I/O	FT	PA12	USART1_RTS TIM1_ETR CAN_TX	USB_DP
											EVENT_OUT	
72	46	46	34	35	35	23	PA13	I/O	FT	JTMS-SWDIO	JTMS-SWDIO	-
											EVENT_OUT	
73	48	48	36	36	36	24	V _{CAP} (4)	-	-	V _{CAP}	-	-
74	47	47	35	-	-	-	V _{SS_2}	S	-	V _{SS_2}	-	-
75	-	-	-	-	-	17	V _{CC_2}	S	-	V _{CC_2}	-	-
76	49	49	37	37	37	25	PA14	I/O	FT	JTCK-SWCLK	JTCK-SWCLK	-
											EVENT_OUT	
77	50	50	38	37	38	26	PA15	I/O	FT	JTDI	JTDI SPI3_NSS SPI1_NSS TIM2_CH1_ETR I ² S3_WS	-
											EVENT_OUT	
78	51	51	-	38	-	-	PC10	I/O	FT	PC10	USART4_TX USART3_TX SDIO_D2	-
											EVENT_OUT	
79	52	52	-	39	-	-	PC11	I/O	FT	PC11	USART4_RX USART3_RX SDIO_D3	-
											EVENT_OUT	
80	53	53	-	-	-	-	PC12	I/O	FT	PC12	USART5_TX USART3_CK SDIO_CK	-
											EVENT_OUT	
81	5	-	5	-	-	2	PD0	I/O	FT	-	CAN_RX	-
											EVENT_OUT	
82	6	-	6	-	-	3	PD1	I/O	FT	-	CAN_TX	-
											EVENT_OUT	

Package Type							Reset	Ports Type	Ports structure	Reset function ⁽¹⁾	Port Function	
LQFP100 V1	LQFP64 R1	LQFP64 R2	LQFP48 C1	LQFP48 C2	QFN48 C1	QFN32 K1					Multiplexed function	Additional function
83	54	54	-	-	-	-	PD2	I/O	FT	PD2	TIM3_ETR USART5_RX SDIO_CMD EVENT_OUT	-
84	-	-	-	-	-	-	PD3	I/O	FT	PD3	USART2_CTS USART5_CK ESMC_SS2 EVENT_OUT	-
85	-	-	-	-	-	-	PD4	I/O	FT	PD4	USART2_RTS USART5_CTS ESMC_IO4 EVENT_OUT	-
86	-	-	-	-	39	-	PD5	I/O	FT	PD5	USART2_TX USART5_RTS ESMC_IO5 EVENT_OUT	-
87	-	-	-	-	40	-	PD6	I/O	FT	PD6	USART2_RX ESMC_IO6 EVENT_OUT	-
88	-	-	-	-	-	-	PD7	I/O	FT	PD7	USART2_CK ESMC_IO7 EVENT_OUT	-
89	55	55	39	40	41	27	PB3	I/O	FT	JTDO	JTDO-TRAC- ESMC SPI3_SCK SPI1_SCK TIM2_CH2 EVENT_OUT	-
90	56	56	40	41	42	28	PB4	I/O	FT	NJTRST	NJTRST SPI3_MISO SPI1_MISO TIM3_CH1 EVENT_OUT	-
91	57	57	41	42	43	29	PB5	I/O	-	PB5	I ² C1_SMBA SPI3_MOSI SPI1_MOSI TIM3_CH2 I ² S3_SD EVENT_OUT	-
92	58	58	42	43	44	30	PB6	I/O	FT	PB6	I ² C1_SCL USART1_TX TIM4_CH1 EVENT_OUT	-
93	59	59	43	44	45	-	PB7	I/O	FT	PB7	I ² C1_SDA USART1_RX TIM4_CH2	-

Package Type							Reset	Ports Type	Ports structure	Reset function ⁽¹⁾	Port Function	
LQFP100 V1	LQFP64 R1	LQFP64 R2	LQFP48 C1	LQFP48 C2	QFN48 C1	QFN32 K1					Multiplexed function	Additional function
											EVENT_OUT	
94	60	60	44	-	-	31	BOOT0	I	-	BOOT0	-	-
95	61	61	45	45	46	32	PB8	I/O	FT	PB8	I ² C1_SCL	-
											TIM4_CH3	
											TIM10_CH1	
											CAN_RX	
											SDIO_D4	
											EVENT_OUT	
96	62	62	46	46	47	32	PB9	I/O	FT	PB9	I ² C1_SDA	-
											TIM4_CH4	
											TIM11_CH1	
											CAN_TX	
											SDIO_D45	
											EVENT_OUT	
97	-	-	-	-	-	-	PE0	I/O	FT	PE0	TIM4_ETR	-
											EVENT_OUT	
98	-	-	-	-	-	-	PE1	I/O	FT	PE1	EVENT_OUT	-
99	63	63	47	47	-	-	V _{SS_3}	S	-	V _{SS_3}	-	-
100	64	64	48	48	48	-	V _{CC_3}	S	-	V _{CC_3}	-	-

- The available functions depend on the selected device. If multiple peripherals share the same I/O pins, to avoid conflicts between these alternate functions, only one peripheral can be enabled at a time via the peripheral clock enable bit (in the corresponding RCC peripheral clock enable register).
- PC13, PC14 and PC15 are powered via a power switch. Due to the limited current sink capability of this switch (3 mA), the following limitations exist when using GPIO PC13 to PC15 in output mode:
 - the rate must not exceed 2 MHz and the maximum load is 30 pF.
 - These I/Os cannot be used as current sources (e.g. for driving LEDs).
- The main function after the first backup domain power-up. After this it depends on the contents of the backup registers, even after a reset (as these registers are not controlled by the main area reset).
- LDO core-powered output (internal circuits only, external 0.1 ~ 1 µF decoupling capacitor required).

3.1. Port A multiplexed function mapping

Table 3-3 Port A multiplexed function mapping

PortA	AF0	AF1	AF2	AF3	AF4	AF5	AF6	AF7	AF8	AF9	AF10	AF11	AF12	AF13	AF14	AF15
PA0	-	-	USART2_CTS	-	-	TIM8_ETR	TIM2_CH1_ETR	TIM5_CH1	-	-	-	-	-	-	-	EVENT_OUT
PA1	-	-	USART2_RTS	-	-	-	TIM2_CH2	TIM5_CH2	-	-	-	-	-	-	-	EVENT_OUT
PA2	-	-	USART2_TX	-	-	-	TIM2_CH3	TIM5_CH3	TIM9_CH1	-	ESMC_SS0	-	-	-	-	EVENT_OUT
PA3	-	-	USART2_RX	-	-	-	TIM2_CH4	TIM5_CH4	TIM9_CH2	-	ESMC_CLK	-	-	-	-	EVENT_OUT
PA4	-	-	USART2_CK	SPI1_NSS	-	-	-	-	-	-	-	-	-	-	-	EVENT_OUT
PA5	-	-	-	SPI1_SCK	-	-	-	-	-	-	-	-	-	-	-	EVENT_OUT
PA6	-	-	-	SPI1_MISO	-	TIM8_BKIN	TIM3_CH1	-	TIM13_CH1	-	ESMC_IO3	-	-	-	-	EVENT_OUT
PA7	-	-	-	SPI1_MOSI	-	TIM8_CH1N	-	-	TIM14_CH1	-	ESMC_IO2	-	-	-	-	EVENT_OUT
PA8	MCO	-	USART1_CK	-	TIM1_CH1	-	-	-	-	-	-	-	-	-	-	EVENT_OUT
PA9	-	-	USART1_TX	-	TIM1_CH2	-	-	-	-	-	-	-	-	-	-	EVENT_OUT
PA10	-	-	USART1_RX	CTC_SYNC	TIM1_CH3	-	-	-	-	-	-	-	-	-	-	EVENT_OUT
PA11	-	-	USART1_CTS	-	TIM1_CH4	-	-	-	-	-	CAN_RX	-	-	-	-	EVENT_OUT
PA12	-	-	USART1_RTS	-	TIM1_ETR	-	-	-	-	-	CAN_TX	-	-	-	-	EVENT_OUT
PA13	JTMS-SWDIO	-	-	-	-	-	-	-	-	-	-	-	-	-	-	EVENT_OUT
PA14	JTCK-SWCLK	-	-	-	-	-	-	-	-	-	-	-	-	-	-	EVENT_OUT
PA15	JTDI	-	SPI3_NSS	SPI1_NSS	-	-	TIM2_CH1_ETR	-	-	-	-	-	-	-	-	EVENT_OUT

3.2. Port B multiplexed function mapping

Table 3-4 Port B multiplexed function mapping

PortB	AF0	AF1	AF2	AF3	AF4	AF5	AF6	AF7	AF8	AF9	AF10	AF11	AF12	AF13	AF14	AF15
PB0	-	-	-	-	TIM1_CH2N	TIM8_CH2N	TIM3_CH3	-	-	-	ESMC_IO1	-	-	-	-	EVENT_OUT
PB1	-	-	-	-	TIM1_CH3N	TIM8_CH3N	-	-	-	-	ESMC_IO0	-	-	-	-	EVENT_OUT
PB2	-	-	-	-	-	-	-	-	-	-	-	-	-	-	-	EVENT_OUT
PB3	JTDO-TRACESWO	-	SPI3_SCK	SPI1_SCK	-	-	TIM2_CH2	-	-	-	-	-	-	-	-	EVENT_OUT
PB4	NJTRST	-	SPI3_MISO	SPI1_MISO	-	-	TIM3_CH1	-	-	-	-	-	-	-	-	EVENT_OUT

PortB	AF0	AF1	AF2	AF3	AF4	AF5	AF6	AF7	AF8	AF9	AF10	AF11	AF12	AF13	AF14	AF15
PB5	-	I ² C1_SMBA	SPI3_MOSI	SPI1_MOSI	-	-	TIM3_CH2	-	-	-	-	-	-	-	-	EVENT_OUT
PB6	-	I ² C1_SCL	USART1_TX	-	-	-	TIM4_CH1	-	-	-	-	-	-	-	-	EVENT_OUT
PB7	-	I ² C1_SDA	USART1_RX	-	-	-	TIM4_CH2	-	-	-	-	-	-	-	-	EVENT_OUT
PB8	-	I ² C1_SCL	-	-	-	-	TIM4_CH3	-	TIM10_CH1	-	CAN_RX	SDIO_D4	-	-	-	EVENT_OUT
PB9	-	I ² C1_SDA	-	-	-	-	TIM4_CH4	-	TIM11_CH1	-	CAN_TX	SDIO_D5	-	-	-	EVENT_OUT
PB10	-	I ² C2_SCL	USART3_TX	-	-	-	TIM2_CH3	-	-	-	ESMC_CLK	-	-	-	-	EVENT_OUT
PB11	-	I ² C2_SDA	USART3_RX	-	-	-	TIM2_CH4	-	-	-	ESMC_SS1	-	-	-	-	EVENT_OUT
PB12	-	I ² C2_SMBA	USART3_CK	SPI2_NSS	TIM1_BKIN	-	-	TIM5_ETR	-	-	-	-	-	-	I2S2_WS	EVENT_OUT
PB13	-	-	USART3_CTS	SPI2_SCK	TIM1_CH1N	-	-	-	-	-	-	-	-	-	I2S2_CK	EVENT_OUT
PB14	-	-	USART3_RTS	SPI2_MISO	TIM1_CH2N	-	-	-	TIM12_CH1	-	-	-	-	-	-	EVENT_OUT
PB15	-	-	-	SPI2_MOSI	TIM1_CH3N	-	-	-	TIM12_CH2	-	-	-	-	-	I2S2_SD	EVENT_OUT

3.3. Port C multiplexing function mapping

Table 3-5 Port C multiplexing function mapping

PortC	AF0	AF1	AF2	AF3	AF4	AF5	AF6	AF7	AF8	AF9	AF10	AF11	AF12	AF13	AF14	AF15
PC0	-	-	-	-	-	-	-	-	-	-	-	-	-	-	-	EVENT_OUT
PC1	-	-	-	-	-	-	-	-	-	-	ESMC_IO4	-	-	-	-	EVENT_OUT
PC2	-	-	-	-	-	-	-	-	-	-	ESMC_IO5	-	-	-	-	EVENT_OUT
PC3	-	-	-	-	-	-	-	-	-	-	ESMC_IO6	-	-	-	-	EVENT_OUT
PC4	-	-	-	-	-	-	-	-	-	-	ESMC_IO7	-	-	-	-	EVENT_OUT
PC5	-	-	-	-	-	-	-	-	-	-	-	-	-	-	I2S1_MCK	EVENT_OUT
PC6	-	USART4_CK	-	-	-	TIM8_CH1	TIM3_CH1	-	-	-	-	SDIO_D6	-	-	I2S2_MCK	EVENT_OUT
PC7	-	USART4_CTS	-	-	-	TIM8_CH2	TIM3_CH2	-	-	-	-	SDIO_D7	-	-	-	EVENT_OUT
PC8	-	USART4_RTS	-	-	-	TIM8_CH3	TIM3_CH3	-	-	-	-	SDIO_D0	-	-	-	EVENT_OUT
PC9	-	-	-	-	-	TIM8_CH4	TIM3_CH4	-	-	-	-	SDIO_D1	-	-	-	EVENT_OUT
PC10	-	USART4_TX	USART3_TX	-	-	-	-	-	-	-	-	SDIO_D2	-	-	I2S1_CK	EVENT_OUT
PC11	-	USART4_RX	USART3_RX	-	-	-	-	-	-	-	-	SDIO_D3	-	-	I2S1_WS	EVENT_OUT
PC12	-	USART5_TX	USART3_CK	-	-	-	-	-	-	-	-	SDIO_CK	-	-	I2S1_SD	EVENT_OUT
PC13	-	-	-	-	-	-	-	-	-	-	-	-	-	-	-	EVENT_OUT

PortC	AF0	AF1	AF2	AF3	AF4	AF5	AF6	AF7	AF8	AF9	AF10	AF11	AF12	AF13	AF14	AF15
PC14	-	-	-	-	-	-	-	-	-	-	-	-	-	-	-	EVENT_OUT
PC15	-	-	-	-	-	-	-	-	-	-	-	-	-	-	-	EVENT_OUT

3.4. Port D multiplexing function mapping

Table 3-6 Port D multiplexing function mapping

PortD	AF0	AF1	AF2	AF3	AF4	AF5	AF6	AF7	AF8	AF9	AF10	AF11	AF12	AF13	AF14	AF15
PD0	-	-	-	-	-	-	-	-	-	-	CAN_RX	-	-	-	-	EVENT_OUT
PD1	-	-	-	-	-	-	-	-	-	-	CAN_TX	-	-	-	-	EVENT_OUT
PD2	-	USART5_RX	-	-	-	-	TIM3_ETR	-	-	-	-	SDIO_CMD	-	-	-	EVENT_OUT
PD3	-	USART5_CK	USART2_CTS	-	-	-	-	-	-	-	ESMC_SS2	-	-	-	-	EVENT_OUT
PD4	-	USART5_CTS	USART2_RTS	-	-	-	-	-	-	-	ESMC_IO4	-	-	-	-	EVENT_OUT
PD5	-	USART5_RTS	USART2_TX	-	-	-	-	-	-	-	ESMC_IO5	-	-	-	-	EVENT_OUT
PD6	-	-	USART2_RX	-	-	-	-	-	-	-	ESMC_IO6	-	-	-	-	EVENT_OUT
PD7	-	-	USART2_CK	-	-	-	-	-	-	-	ESMC_IO7	-	-	-	-	EVENT_OUT
PD8	-	-	USART3_TX	-	-	-	-	-	-	-	-	-	-	-	-	EVENT_OUT
PD9	-	-	USART3_RX	-	-	-	-	-	-	-	-	-	-	-	-	EVENT_OUT
PD10	-	-	USART3_CK	-	-	-	-	-	-	-	-	-	-	-	-	EVENT_OUT
PD11	-	-	USART3_CTS	-	-	-	-	TIM5_ETR	-	-	-	-	-	-	-	EVENT_OUT
PD12	-	-	USART3_RTS	-	-	-	TIM4_CH1	-	-	-	-	-	-	-	-	EVENT_OUT
PD13	-	-	-	-	-	-	TIM4_CH2	-	-	-	-	-	-	-	-	EVENT_OUT
PD14	-	-	-	-	-	-	TIM4_CH3	-	-	-	-	-	-	-	-	EVENT_OUT
PD15	-	-	-	-	-	-	TIM4_CH4	-	-	-	-	-	-	-	-	EVENT_OUT

3.5. Port E multiplexing function mapping

Table 3-7 Port E multiplexing function mapping

PortE	AF0	AF1	AF2	AF3	AF4	AF5	AF6	AF7	AF8	AF9	AF10	AF11	AF12	AF13	AF14	AF15
PE0	-	-	-	-	-	-	TIM4_ETR	-	-	-	-	-	-	-	-	EVENT_OUT
PE1	-	-	-	-	-	-	-	-	-	-	-	-	-	-	-	EVENT_OUT

PortE	AF0	AF1	AF2	AF3	AF4	AF5	AF6	AF7	AF8	AF9	AF10	AF11	AF12	AF13	AF14	AF15
PE2	TRACECK	-	-	-	-	-	-	-	-	-	-	-	-	-	-	EVENT_OUT
PE3	TRACED0	-	-	-	-	-	-	-	-	-	-	-	-	-	-	EVENT_OUT
PE4	TRACED1	-	-	-	-	-	-	-	-	-	-	-	-	-	-	EVENT_OUT
PE5	TRACED2	-	-	-	-	-	-	-	TIM9_CH1	-	-	-	-	-	-	EVENT_OUT
PE6	TRACED3	-	-	-	-	-	-	-	TIM9_CH2	-	-	-	-	-	-	EVENT_OUT
PE7	-	-	-	-	TIM1_ETR	-	-	-	-	-	-	-	-	-	-	EVENT_OUT
PE8	-	-	-	-	TIM1_CH1N	-	-	-	-	-	-	-	-	-	-	EVENT_OUT
PE9	-	-	-	-	TIM1_CH1	-	-	-	-	-	-	-	-	-	-	EVENT_OUT
PE10	-	-	-	-	TIM1_CH2N	-	-	-	-	-	ESMC_CLK	-	-	-	-	EVENT_OUT
PE11	-	-	-	-	TIM1_CH2	-	-	-	-	-	ESMC_SS3	-	-	-	-	EVENT_OUT
PE12	-	-	-	-	TIM1_CH3N	-	-	-	-	-	ESMC_IO0	-	-	-	-	EVENT_OUT
PE13	-	-	-	-	TIM1_CH3	-	-	-	-	-	ESMC_IO1	-	-	-	-	EVENT_OUT
PE14	-	-	-	-	TIM1_CH4	-	-	-	-	-	ESMC_IO2	-	-	-	-	EVENT_OUT
PE15	-	-	-	-	TIM1_BKIN	-	-	-	-	-	ESMC_IO3	-	-	-	-	EVENT_OUT

4. Memory Map

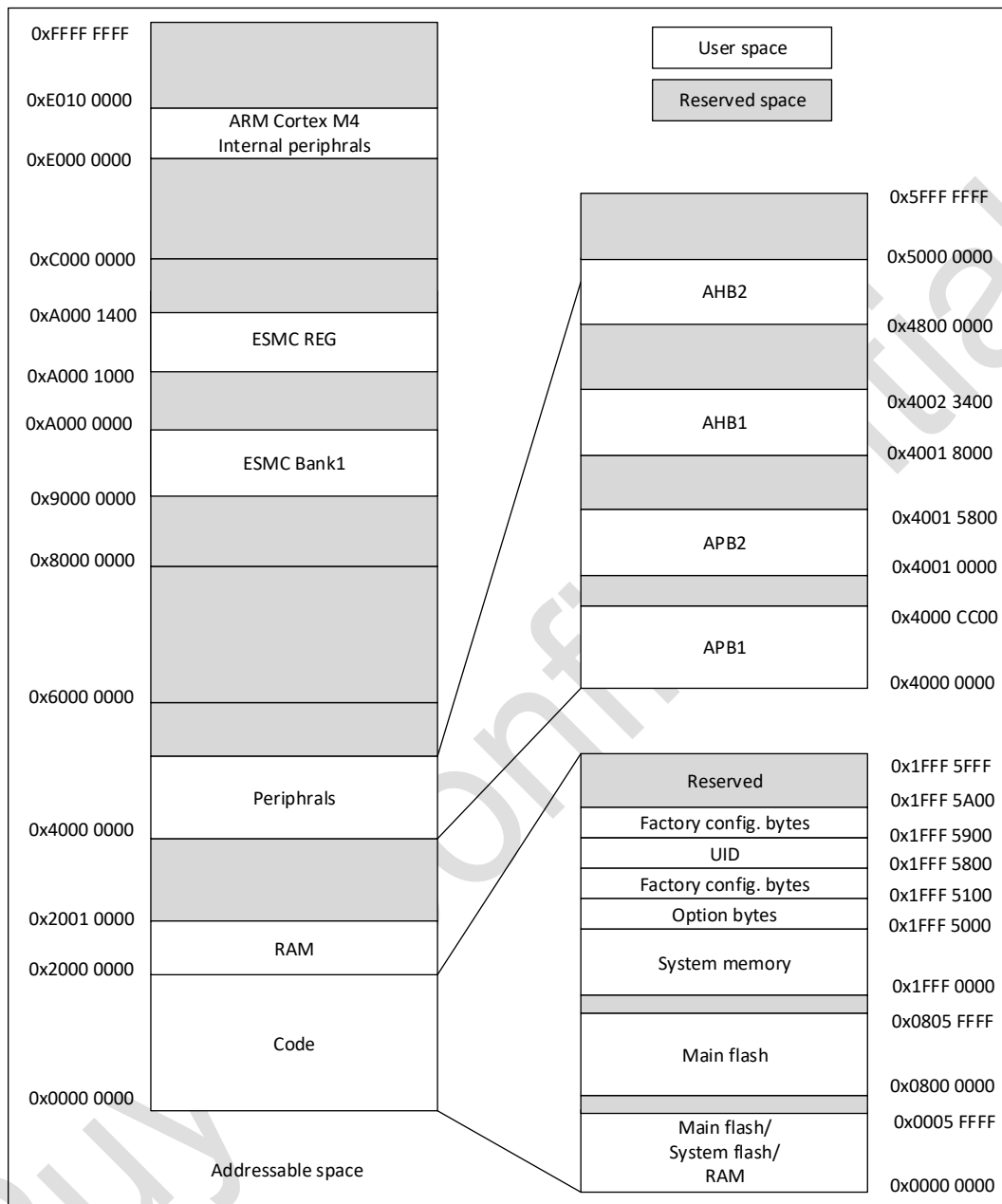

Figure 4-1 Memory Map

Table 4-1 Memory Address

Type	Boundary Address	Size	Memory Area	Description
SRAM	0x2001 0000-0x3FFF FFFF	511 Mbytes	Reserved	1. Response error is generated when the CPU reads or writes to the space, which leads to a HardFault exception; 2. TEIF status bit is generated during DMA access;
	0x2000 0000-0x2000 FFFF	64 Kbytes	SRAM	If the hardware power-up configures the SRAM to 64 KBytes, then the SRAM address space is 0x2000 0000-0x2000 FFFF
Code	0x1FFF 5A00-0x1FFF 5FFF	1.5 Kbytes	Reserved	-
	0x1FFF 5900-0x1FFF 59FF	256 Bytes	Factory config. bytes	-
	0x1FFF 5800-0x1FFF 58FF	256 Bytes	UID bytes	Unique ID
	0x1FFF 5700-0x1FFF 57FF	256 Bytes	Factory config. bytes	-
	0x1FFF 5600-0x1FFF 56FF	256 Bytes	HSI8M Trim	-
	0x1FFF 5500-0x1FFF 55FF	256 Bytes	Factory config. bytes	-
	0x1FFF 5400-0x1FFF 54FF	256 Bytes	Factory config. bytes	-
	0x1FFF 5300-0x1FFF 53FF	256 Bytes	Factory config. bytes	-
	0x1FFF 5200-0x1FFF 52FF	256 Bytes	Factory config. bytes	-
	0x1FFF 5100-0x1FFF 51FF	256 Bytes	Factory config. bytes	-
	0x1FFF 5000-0x1FFF 50FF	256 Bytes	Option bytes	Chip hardware and software option bytes information;
	0x1FFF 0000-0x1FFF 4FFF	24 Kbytes	System memory	Store the boot loader
	0x0806 0000-0x1FFE FFFF	383 MBytes	Reserved	-
	0x0800 0000-0x0805 FFFF	384 Kbytes	Main flash memory	-
	0x0006 0000-0x07FF FFFF	8 Mbytes	Reserved	1. Response error is generated when the CPU reads or writes to the space, which leads to a HardFault exception; 2. TEIF status bit is generated during DMA access;
	0x0000 0000-0x0005 FFFF	384 Kbytes	The choices according to Boot configuration are: 1) Main flash memory 2) System memory 3) SRAM	-

1. Except for the above space, the rest of the space marked as reserved cannot be written, read as 0, and generate a response error.

Table 4-2 Peripheral register address

Memory start and stop addresses	Peripherals	Bus	Register Map
0xA000 1000 - 0xA000 13FF	ESMC	AHB	-
0x4002 3400 - 0x5FFF FFFF	Reserved	AHB2	-
0x4800 1000 - 0x4800 13FF	GPIOE		-
0x4800 0C00 - 0x4800 0FFF	GPIOD		-
0x4800 0800 - 0x4800 0BFF	GPIOC		-
0x4800 0400 - 0x4800 07FF	GPIOB		-
0x4800 0000 - 0x4800 03FF	GPIOA		-
0x4002 3400 - 0x47FF FFFF	Reserved		AHB1
0x4002 3000 - 0x4002 33FF	CRC	-	
0x4002 2400 - 0x4002 2FFF	Reserved	-	
0x4002 2000 - 0x4002 23FF	FMC	-	

Memory start and stop addresses	Peripherals	Bus	Register Map
0x4002 1400 - 0x4002 1FFF	Reserved	APB2	-
0x4002 1000 - 0x4002 13FF	RCC		-
0x4002 0800 - 0x4002 0FFF	Reserved		-
0x4002 0400 - 0x4002 07FF	DMA2		-
0x4002 0000 - 0x4002 03FF	DMA1		-
0x4001 8400 - 0x4001 FFFF	Reserved		-
0x4001 8000 - 0x4001 83FF	SDIO		-
0x4001 5800 - 0x4001 7FFF	Reserved		-
0x4001 5400 - 0x4001 57FF	TIMER11		-
0x4001 5000 - 0x4001 53FF	TIMER10		-
0x4001 4C00 - 0x4001 4FFF	TIMER9		-
0x4001 4000 - 0x4001 4BFF	Reserved		-
0x4001 3C00 - 0x4001 3FFF	ADC3		-
0x4001 3800 - 0x4001 3BFF	USART1		-
0x4001 3400 - 0x4001 37FF	TIMER8		-
0x4001 3000 - 0x4001 33FF	SPI1		-
0x4001 2C00 - 0x4001 2FFF	TIMER1		-
0x4001 2800 - 0x4001 2BFF	ADC2		-
0x4001 2400 - 0x4001 27FF	ADC1		-
0x4001 0800 - 0x4001 23FF	Reserved		-
0x4001 0400 - 0x4001 07FF	EXTI	-	
0x4001 0000 - 0x4001 03FF	SYSCFG	-	
0x4000 CC00 - 0x4000 FFFF	Reserved	APB1	-
0x4000 C800 - 0x4000 CBFF	CTC		-
0x4000 7800 - 0x4000 C7FF	Reserved		-
0x4000 7400 - 0x4000 77FF	Reserved		-
0x4000 7000 - 0x4000 73FF	PWR		-
0x4000 6C00 - 0x4000 6FFF	BKP		-
0x4000 6800 - 0x4000 6BFF	Reserved		-
0x4000 6400 - 0x4000 67FF	CANFD		-
0x4000 6000 - 0x4000 63FF	USBD/CANFD shared 512 Bytes SRAM		-
0x4000 5C00 - 0x4000 5FFF	USBD		-
0x4000 5800 - 0x4000 5BFF	I ² C2		-
0x4000 5400 - 0x4000 57FF	I ² C1		-
0x4000 5000 - 0x4000 53FF	UASRT5		-
0x4000 4C00 - 0x4000 4FFF	UASRT4		-
0x4000 4800 - 0x4000 4BFF	USART3		-
0x4000 4400 - 0x4000 47FF	USART2		-
0x4000 4000 - 0x4000 43FF	Reserved		-
0x4000 3C00 - 0x4000 3FFF	SPI3/I2S		-
0x4000 3800 - 0x4000 3BFF	SPI2/I2S		-
0x4000 3400 - 0x4000 37FF	Reserved		-
0x4000 3000 - 0x4000 33FF	IWDG	-	
0x4000 2C00 - 0x4000 2FFF	WWDG	-	
0x4000 2800 - 0x4000 2BFF	RTC	-	
0x4000 2400 - 0x4000 27FF	Reserved	-	

Memory start and stop addresses	Peripherals	Bus	Register Map
0x4000 2000 - 0x4000 23FF	TIMER14		-
0x4000 1C00 - 0x4000 1FFF	TIMER13		-
0x4000 1800 - 0x4000 1BFF	TIMER12		-
0x4000 1400 - 0x4000 17FF	TIMER7		-
0x4000 1000 - 0x4000 13FF	TIMER6		-
0x4000 0C00 - 0x4000 0FFF	TIMER5		-
0x4000 0800 - 0x4000 0BFF	TIMER4		-
0x4000 0400 - 0x4000 07FF	TIMER3		-
0x4000 0000 - 0x4000 03FF	TIMER2		-

1. The above table AHB marked as Reserved address space, can not write operation, read back to 0, and generate hardfault.
2. Not only supports 32-bit word access, but also supports half-word and byte access.
3. Not only supports 32-bit word access, but also supports half-word access.

5. Electrical Characteristics

5.1. Parameter conditions

Unless otherwise specified, all voltages are referenced to V_{SS} .

5.1.1. Minimum and maximum values

Unless otherwise specified, all devices have been tested during production at $T_A = 25\text{ °C}$ and $T_A = T_{Amax}$ (depending on the temperature range of the selected device) for minimum and maximum values that can be guaranteed under worst-case ambient temperature, supply voltage and clock frequency conditions.

The data based on characterization results, design simulations and/or technical characteristics are described in the footnotes of the tables and have not been tested in production. On the basis of the characterization, the minimum and maximum values are obtained by averaging the sample tests plus or minus three times the standard deviation (mean $\pm 3\sigma$).

5.1.2. Typical values

Unless otherwise noted, typical data is measured at $T_A = 25\text{ °C}$ and $V_{CC} = 3.3\text{ V}$ (for the $2.0\text{ V} \leq V_{CC} \leq 3.6\text{ V}$ voltage range). These data are untested and are for design reference only.

Typical ADC accuracy values are determined by sampling a standard diffusion batch and performing a characterization over the entire temperature range, where 95% of the devices have an error less than or equal to the specified value (mean $\pm 2\sigma$).

5.2. Absolute maximum ratings

If the absolute maximum values given in the table below are exceeded, permanent damage to the chip may result. This is only a list of the strength levels that can be withstood, and does not mean that the device will function without error under these conditions. Prolonged operation at the maximum values may affect the reliability of the chip.

Table 5-1 Voltage Characteristics ⁽¹⁾

Symbol	Description	Minimum	Maximum	Unit
$V_{CC}-V_{SS}$	External power supply voltage (Including V_{CC} , V_{CCA} , V_{BAT}) ⁽¹⁾	-0.3	4.0	V
$V_{IN}^{(2)}$	FT pin input voltage	$V_{SS} - 0.3$	5.5	
	All other input pin input voltages	$V_{SS} - 0.3$	4.0	
$ DV_{CCx} $	Voltage variation between different V_{CC} pins	-	50	mV
$ V_{SSx}-V_{SS} $	Voltage variation between different ground pins	-	50	

1. The power V_{CC} and ground V_{SS} pins must always be connected to a supply system within the external allowable range.
2. The maximum value of V_{IN} must always follow the maximum allowed injected current value, as shown in the following table.

Table 5-2 Current Characteristics

Symbol	Description	Maximum	Unit
I_{VCC}	Total current flowing into all V_{CC} / V_{CCA} power lines (pull current) ⁽¹⁾	150	mA
I_{VSS}	Total current flowing out of all V_{SS} grounding wires (irrigation current) ⁽¹⁾	150	
I_{IO}	Output potting current for arbitrary I/O and control pins	25	
	Output pull current for arbitrary I/O and control pins	-25	
$I_{INJ(PIN)}^{(2)(6)}$	5 V-tolerant pin injection current ⁽³⁾	-5/+0	
	All other pins inject current ⁽⁴⁾	± 5	
$\Sigma I_{INJ(PIN)}$	Total injected current on all I/O and control pins ⁽⁵⁾	± 25	

1. The power V_{CC} and ground V_{SS} pins must always be connected to an external supply system within the allowed range.
2. The IO type can be referred to the terminology and symbols of the pin definition.
3. Reverse injection of current can interfere with the analog performance of the device.
4. Forward injection is not possible on these I/Os and will not occur when the input voltage is below a specified maximum.
5. Forward injection current occurs when $V_{IN} > V_{CCA}$; reverse injection current occurs when $V_{IN} < V_{SS}$.
6. When multiple inputs have simultaneous injection currents, the maximum value of $\Sigma I_{INJ(PIN)}$ is equal to the sum of the absolute values of the forward injection current and the reverse injection current (instantaneous value).

Table 5-3 Temperature Characteristics

Symbol	Description	Maximum	Unit
T_{STG}	Storage temperature range	-65 ~ 150	°C
T_J	Maximum junction temperature	150	°C

5.3. Operating conditions

5.3.1. General working conditions

Table 5-4 General working conditions

Symbol	Parameter	Condition	Minimum	Maximum	Unit
f_{HCLK}	AHB clock frequency	-	0	144	MHz
f_{PCLK1}	APB1 clock frequency	-	0	144	
f_{PCLK2}	APB2 clock frequency	-	0	144	
V_{CC}	Operating Voltage	-	2.0	3.6	V
$V_{CCA}^{(1)}$	Analog circuit operating voltage	Must be the same as V_{CC}	2.0	3.6	V
V_{BAT}	Backup section operating voltage	-	2.0	3.6	V
$P_D^{(2)}$	Power consumption $T_A = 85\text{ °C}$	LQFP100	-	-	mW
		LQFP64	-	-	
T_A	Environmental temperature	Maximum power consumption when operating	-40	85	°C
		Lowest power consumption operation	-40	105	
T_J	Junction temperature range	Maximum power consumption when operating	-40	90	°C
		Lowest power consumption operation	-40	110	

1. It is recommended to use the same power supply for V_{CC} and V_{CCA} , allowing a maximum difference of 300 mV between V_{CC} and V_{CCA} during power-up and normal operation.
2. If T_A is low, higher P_D values are allowed as long as T_J does not exceed T_{Jmax} .

5.3.2. Operating conditions at power-up / power-down

Table 5-5 Operating conditions at power-up / power-down

Symbol	Parameter	Condition	Minimum	Maximum	Unit
t_{VCC}	V_{CC} rise time rate	-	0	∞	$\mu\text{s/V}$
	V_{CC} fall time rate	V_{CC} , V_{BAT} drop synchronously	20	∞	
		V_{CC} drops, V_{BAT} holds	100	∞	

5.3.3. Reset and voltage control module features

Table 5-6 Reset and voltage control module features

Symbol	Parameter	Condition	Minimum	Typical	Maximum	Unit
V_{PVD}	Programmable voltage detector level selection	PLS[2:0]=000 (Rising edge)	1.7	1.8	1.9	V
		PLS[2:0]=000 (Falling edge)	1.6	1.7	1.8	V
		PLS[2:0]=001 (Rising edge)	1.9	2	2.1	V
		PLS[2:0]=001 (Falling edge)	1.8	1.9	2	V
		PLS[2:0]=010 (Rising edge)	2.1	2.2	2.3	V
		PLS[2:0]=010 (Falling edge)	2	2.1	2.2	V
		PLS[2:0]=011 (Rising edge)	2.3	2.4	2.5	V
		PLS[2:0]=011 (Falling edge)	2.2	2.3	2.4	V
		PLS[2:0]=100 (Rising edge)	2.5	2.6	2.7	V
		PLS[2:0]=100 (Falling edge)	2.4	2.5	2.6	V
		PLS[2:0]=101 (Rising edge)	2.7	2.8	2.9	V
		PLS[2:0]=101 (Falling edge)	2.6	2.7	2.8	V
		PLS[2:0]=110 (Rising edge)	2.9	3	3.1	V
		PLS[2:0]=110 (Falling edge)	2.8	2.9	3	V
		PLS[2:0]=111 (Rising edge)	3.1	3.2	3.3	V
		PLS[2:0]=111 (Falling edge)	3	3.1	3.2	V
$V_{PVDhyst}^{(1)}$	PVD hysteresis	-	-	100	-	mV
$V_{POR/PDR}$	Power-up/power-down reset threshold	Falling edge	1.58	1.63	1.68	V
		Rising edge	1.56	1.61	1.66	V
$V_{PDRhyst}^{(1)}$	PDR hysteresis	-	-	20	-	mV
$T_{RSTTEMPO}^{(2)}$	Reset duration	-	1	2.5	4.5	ms

1. Guaranteed by design, not tested in production.
2. Reset duration is measured from power-up (POR reset or wake-up from V_{BAT}) to the moment the first instruction is read by the user application code.

5.3.4. Operating current characteristics

Current consumption is affected by several parameters and factors, including operating voltage, ambient temperature, I/O pin load, device software configuration, operating frequency, I/O pin switching rate, location of the program in memory, and the code executed. Current consumption measurements for the various modes of operation described in this section are derived from a streamlined set of code.

Maximum current consumption

The microcontroller is in the following conditions:

- All I/O pins are in input mode with static values (no load) on V_{CC} or V_{SS} .
- All peripherals are off, unless otherwise noted.
- Flash memory access time is adjusted to the frequency of f_{HCLK} (0 wait cycles at 0 ~ 28 MHz, 1 wait cycle at 28 ~ 60 MHz, 3 wait cycles at 60 ~ 90 MHz, 4 wait cycles at 90 ~ 120 MHz, 5 wait cycles at 120 ~ 140 MHz, and 6 wait cycles at greater than 140 MHz).
- Unless otherwise noted, $V_{CC} = 3.6$ V, maximum at maximum ambient temperature (T_A), typical value is $T_A = 25^\circ\text{C}$ and $V_{CC} = 3.3$ V.
- Command Prefetch is on. When the peripheral is on: $f_{PCLK1} = f_{HCLK}$.

Note: The command prefetch function must be set before setting the clock and bus divider.

Table 5-7 FLASH down operation mode current

Symbol	Parameter	Condition	Frequency f_{HCLK}	Typical	Maximum ⁽¹⁾		Unit
				$T_A = 25^\circ\text{C}$	$T_A = 85^\circ\text{C}$	$T_A = 105^\circ\text{C}$	
I_{CC}	Supply current in operation mode	External clock ⁽²⁾ , All peripheral enable , FLASH operation	144 MHz	25.60	-	-	mA
			96 MHz	18.24	-	-	
			64 MHz	13.20	-	-	
			48 MHz	11.32	-	-	
			32 MHz	8.31	-	-	
			16 MHz	5.43	-	-	
			8 MHz	1.99	-	-	
		External clock ⁽²⁾ , All peripherals disabled, FLASH running	144 MHz	15.09	-	-	
			96 MHz	11.07	-	-	
			64 MHz	8.37	-	-	
			48 MHz	7.50	-	-	
			32 MHz	5.71	-	-	
			16 MHz	3.91	-	-	
			8 MHz	1.35	-	-	

Table 5-8 Operating mode current under RAM

Symbol	Parameter	Condition ⁽³⁾	Frequency f _{HCLK}	Typical		Maximum ⁽¹⁾		Unit
				T _A = 25°C	T _A = 85°C	T _A = 105°C		
I _{CC}	Supply current in operation mode	External clock ⁽²⁾ , All peripheral enable	144 MHz	24.61	-	-	mA	
			96 MHz	17.55	-	-		
			64 MHz	12.78	-	-		
			48 MHz	10.83	-	-		
			32 MHz	7.99	-	-		
			16 MHz	3.92	-	-		
			8 MHz	2.09	-	-		
		External clock ⁽²⁾ , All peripherals disabled	144 MHz	14.39	-	-		
			96 MHz	10.68	-	-		
			64 MHz	8.07	-	-		
			48 MHz	7.33	-	-		
			32 MHz	5.65	-	-		
			16 MHz	2.68	-	-		
			8 MHz	1.49	-	-		

1. Derived from feature evaluation, not tested in production.
2. External clock is 16 MHz and PLL is enabled when f_{HCLK} > 8 MHz.
3. 8 MHz is the internal HSI clock.

Table 5-9 sleep mode current

Symbol	Parameter	Condition	Frequency f _{HCLK}	Typical		Maximum ⁽¹⁾		Unit
				T _A = 25°C	T _A = 85°C	T _A = 105°C		
I _{CC}	Sleep mode power supply	External clock, All peripheral enable	144 MHz	19.37	-	-	mA	
			96 MHz	14.07	-	-		
			64 MHz	10.44	-	-		
			48 MHz	7.21	-	-		
			32 MHz	5.45	-	-		
			16 MHz	3.32	-	-		
			8 MHz	1.82	-	-		
		External clock, All peripherals disabled	144 MHz	6.60	-	-		
			96 MHz	4.98	-	-		
			64 MHz	3.95	-	-		
			48 MHz	3.41	-	-		
			32 MHz	2.86	-	-		
			16 MHz	1.95	-	-		
			8 MHz	1.07	-	-		

1. The data is based on assessment results and is not tested in production.

Table 5-10 Shutdown and standby mode current

Symbol	Parameter	Condition	Typical ⁽¹⁾			Maximum ⁽²⁾		Unit
			V _{CC} /V _{BAT} = 2.0 V	V _{CC} /V _{BAT} = 2.4 V	V _{CC} /V _{BAT} = 3.3 V	T _A = 85°C	T _A = 105°C	
I _{CC}	Shutdown mode supply current	LDO operation mode, internal high-speed oscillator, internal	432.00	-	-	-	-	uA

Symbol	Parameter	Condition	Typical ¹⁾			Maximum ²⁾		Unit
			V _{CC} /V _{BAT} = 2.0 V	V _{CC} /V _{BAT} = 2.4 V	V _{CC} /V _{BAT} = 3.3 V	T _A = 85 °C	T _A = 105 °C	
		low-speed oscillator and high-speed oscillator off, f _{CK} = 8 MHz						
		LDO low power mode, internal high speed oscillator, internal low speed oscillator and high speed oscillator off	370.00	-	-	-	-	
	Standby mode power supply current	Internal low-speed oscillator and IWDTON	4.80	-	-	-	-	
		Internal low-speed oscillator on, IWDTON	4.80	-	-	-	-	
		Internal low-speed RC oscillator and IWDTON off, low-speed oscillator and RTC off	4.70	-	-	-	-	
I _{CC_VBAT}	Backup domain power supply current	Low-speed oscillator and RTC on	4.80	-	-	-	-	

1. Typical values are tested at T_A = 25 °C.
2. Derived from characterization, not tested in production.

5.3.5. Low power mode wake-up time

Table 5-11 Low power mode wake-up time⁽²⁾

Symbol	Parameter	Typical ⁽³⁾	Unit
t _{WUSLEEP} ⁽¹⁾	Wake up from sleep mode	3.20	μs
t _{WUSTOP} ⁽¹⁾	Wake-up from shutdown mode (LDO operation mode)	6.88	μs
	Wake-up from shutdown mode (LDO low-power mode)	10.66	
t _{WUSTDBY} ⁽¹⁾	Wake up from standby mode	79.50	μs

1. The wake-up time is measured from the start of the wake-up time until the first instruction is read by the user program.
2. The data is based on the test results and is not tested in production.
3. Test data is based on HSI 8 M conditions.

5.3.6. External clock source characteristics

5.3.6.1. External high-speed clock

In the bypass mode of HSE (HSEBYP of RCC_CR is set), the high-speed oscillation circuit inside the chip stops working, and the corresponding IOs are used as standard GPIO.

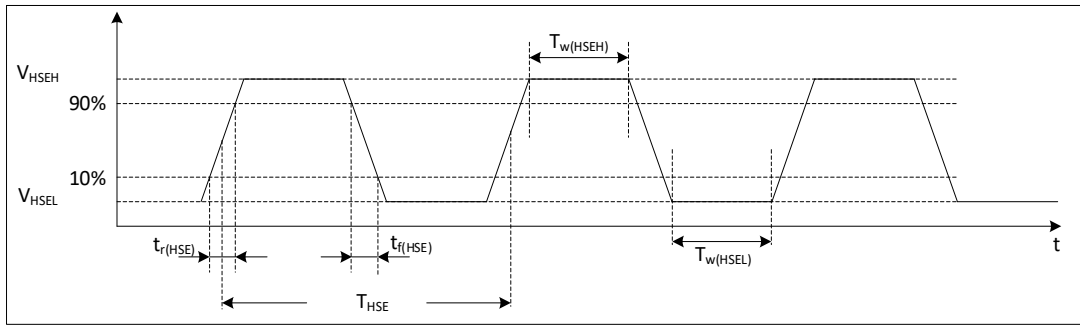

Figure 5-1 External high-speed clock timing diagram

Table 5-12 External high-speed clock characteristics

Symbol	Parameter	Condition	Minimum	Typical	Maximum	Unit
f_{HSE_ext}	User external clock frequency ⁽¹⁾		4	8	32	MHz
V_{HSEH}	OSC_IN input pin high level voltage	-	$0.7 V_{CC}$	-	V_{CC}	V
V_{HSEL}	OSC_IN input pin low level voltage		V_{SS}	-	$0.3 V_{CC}$	
$t_{w(HSE)}$	OSC_IN input pin high low time ⁽¹⁾		5	-	-	ns
$t_{r(HSE)} / t_{f(HSE)}$	OSC_IN input pin rise or fall time ⁽¹⁾		-	-	20	
$C_{in(HSE)}$	OSC_IN input pin capacitance ⁽¹⁾	-	-	5	-	pF
$DuCy_{(HSE)}$	Duty Cycle	-	45	-	55	%
I_L	OSC_IN input pin leakage current	$V_{SS} \leq V_{IN} \leq V_{CC}$	-	-	± 1	μA

1. Guaranteed by design, not tested in production.

5.3.6.2. External low-speed clock

In the bypass mode of LSE (LSEBYP of RCC_BDCR is set), the low-speed start circuit in the chip stops working and the corresponding IOs are used as standard GPIO.

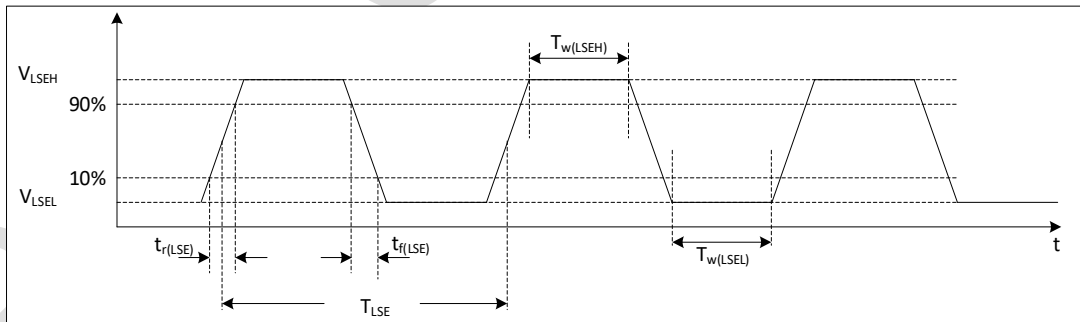

Figure 5-2 External low-speed clock timing diagram

Table 5-13 External low-speed clock characteristics

Symbol	Parameter	Condition	Minimum	Typical	Maximum	Unit
f_{LSE_ext}	User external clock frequency ⁽¹⁾	-	-	32.768	1000	kHz
V_{LSEH}	OSC32_IN input pin high level voltage		$0.7 V_{CC}$	-	V_{CC}	V
V_{LSEL}	OSC32_IN input pin low level voltage		V_{SS}	-	$0.3 V_{CC}$	
$t_{w(LSE)}$	OSC32_IN input pin high low time ⁽¹⁾		450	-	-	ns
$t_{r(LSE)}/t_{f(LSE)}$	OSC32_IN input pin rise or fall time ⁽¹⁾		-	-	50	
$C_{in(LSE)}$	OSC32_IN input pin capacitance ⁽¹⁾	-	-	5	-	pF
DuCy _(LSE)	Duty Cycle	-	30	-	70	%
I_L	OSC32_IN input pin leakage current	$V_{SS} \leq V_{IN} \leq V_{CC}$	-	-	± 1	μA

1. Guaranteed by design, not tested in production.

5.3.6.3. External high-speed crystal

This can be done with an external 32 MHz crystal/ceramic resonator. In this application, the crystal and load capacitor should be as close to the pin as possible to minimize output distortion and start-up stabilization time.

Table 5-14 External high-speed crystal characteristics

Symbol	Parameter	Condition	Minimum	Typical ⁽¹⁾	Maximum	Unit	
f_{OSC_IN}	Oscillator frequency	-	4	8	32	MHz	
R_F	Feedback Resistor	-	-	200	-	k Ω	
I_{DD}	HSE power consumption	CL=12 pF, 32 MHz, HSE_DRV[1:0]=01	-	-	1	mA	
g_m	Oscillator Transduction	Start up	HSE_DRV[1:0]=00	3.5	-	-	mA/V
			HSE_DRV[1:0]=01	5	-	-	mA/V
			HSE_DRV[1:0]=10	7.5	-	-	mA/V
			HSE_DRV[1:0]=11	10	-	-	mA/V
$t_{SU(HSE)}^{(2)}$	Startup time	V_{CC} is stable	-	0.7	-	ms	

1. Given by characteristic evaluation, not tested in production.
2. The relatively low R_F resistance value provides better protection against problems due to inductive leakage and changes in bias conditions when used in humid environments. However, it is recommended to take this parameter into account when designing the MCU if it is to be used in harsh humidity conditions.

5.3.6.4. External low-speed crystal

This can be done with an external 32.768 kHz crystal/ceramic resonator. In this application, the crystal and load capacitor should be as close to the pin as possible to minimize output distortion and start-up stabilization time.

Table 5-15 External low-speed crystal characteristics

Symbol	Parameter	Condition	Minimum	Typical ⁽¹⁾	Maximum	Unit
RF	Feedback Resistor	-	-	5	-	MΩ
I _{DD}	LSE current consumption	LSE_DRV_VBKP[1:0]=00	-	500	-	nA
		LSE_DRV_VBKP[1:0]=01	-	630	-	nA
		LSE_DRV_VBKP[1:0]=10	-	250	-	nA
		LSE_DRV_VBKP[1:0]=11	-	315	-	nA
g _m	Oscillator Transduction	LSE_DRV_VBKP[1:0]=00	8.5	-	-	μA/V
		LSE_DRV_VBKP[1:0]=01	13.5	-	-	μA/V
		LSE_DRV_VBKP[1:0]=10	2.5	-	-	μA/V
		LSE_DRV_VBKP[1:0]=11	3.75	-	-	μA/V
t _{SU(LSE)} ⁽²⁾	Startup time	V _{CC} is stable	-	0.5	-	s

1. Guaranteed by design, not tested in production.
2. The data is based on assessment results and is not tested in production.

5.3.7. Internal high frequency clock source HSI characteristics

Table 5-16 Internal high frequency clock source characteristics

Symbol	Parameter	Condition	Minimum (1)	Typical (1)	Maximum (1)	Unit	
f _{HSI}	Frequency	-	7.96	8	8.04	MHz	
DuCy _(HSI)	Duty Cycle	-	45	-	55	%	
ACC _{HSI}	HSI Oscillator Accuracy	User adjustment using RCC_CR register ⁽²⁾	-	0.5	1 ⁽³⁾	%	
		Factory calibration ⁽⁴⁾	T _A = -40 ~ 105 °C	-	-	-	%
			T _A = -10 ~ 85 °C	-2	-	2	%
			T _A = 0 ~ 70 °C	-	-	-	%
	T _A = 25 °C	-1	-	1	%		
t _{SU(HSI)} ⁽³⁾	HSI oscillator startup time	-	1	-	2	μs	
I _{CC(HSI)} ⁽³⁾	HSI oscillator power consumption	-	-	80	150	μA	

1. Guaranteed by design, not tested in production.
2. V_{CC} = 3.3 V, T_A = -40 ~ 105 °C, unless otherwise noted.
3. Data is based on test results and is not tested in production.

5.3.8. Internal low frequency clock source LSI characteristics

Table 5-17 Internal low frequency clock source LSI characteristics

Symbol	Parameter	Minimum ⁽¹⁾	Typical ⁽¹⁾	Maximum ⁽¹⁾	Unit
f _{LSI} ⁽²⁾	Frequency	30	40	60	kHz
t _{SU(LSI)} ⁽³⁾	LSI oscillator startup time	-	-	85	μs
I _{DD(LSI)} ⁽³⁾	LSI oscillator power consumption	-	0.2	0.3	μA

1. Guaranteed by design, not tested in production.
2. V_{CC} = 3.3 V, T_A = -40 ~ 105 °C, unless otherwise noted.
3. Data is based on test results and is not tested in production.

5.3.9. Phase locked loop (PLL) characteristics

Table 5-18 Phase locked loop characteristics

Symbol	Parameter	Minimum	Typical	Maximum ⁽¹⁾	Unit
f _{PLL_IN}	PLL input clock	8	24	25	MHz
	PLL input clock duty cycle	40	-	60	%
f _{PLL_OUT}	PLL multiplier output clock	48	-	144	MHz
t _{LOCK}	PLL phase lock time	-	25	550	μs
Jitter	Jittering	-	-	180	ps

1. Guaranteed by design, not tested in production.

5.3.10. Memory characteristics

Table 5-19 Memory characteristics

Symbol	Parameter	Condition	Minimum ⁽¹⁾	Typical ⁽¹⁾	Maximum	Unit
PE _{CYC}	Number of erasures	T _A =-40°C ~ 85°C	100	-	-	kcycles
t _{RET}	Data retention time	T _A =85°C, after 1000 erasures	20	-	-	years
		T _A =105°C, after 1000 erasures	10	-	-	
		T _A =55°C, after 10000 erasures	10	-	-	
t _{PROG}	Page programming time	T _A =-40°C ~ 85°C	-	1.5	-	ms
t _{ERASE}	Page erase time	T _A =-40°C ~ 85°C	-	5	-	ms
t _{MERASE}	Full chip erase over time	T _A =-40°C ~ 85°C	-	5	-	ms

1. Guaranteed by design, not tested in production.

5.3.11. ESMC characteristics

Table 5-20 ESMC characteristics in SDR mode ⁽¹⁾

Symbol	Parameter	Condition	Minimum ⁽¹⁾	Typical	Maximum ⁽¹⁾	Unit
F(QCK)	SPI clock frequency	2.0 < V _{CC} < 3.6 V	-	-	70	MHz
t _{w(CKH)}	SPI clock high and low time	2.0 < V _{CC} < 3.6 V	t _{CK} /2-0.5	-	t _{CK} /2+1	ns
t _{w(CKL)}			t _{CK} /2-1	-	t _{CK} /2+0.5	
t _{s(IN)}	Data input setup time	2.0 < V _{CC} < 3.6 V	1	-	-	
t _{h(IN)}	Data input hold time	2.0 < V _{CC} < 3.6 V	5	-	-	
t _{v(OUT)}	Data output valid time	2.0 < V _{CC} < 3.6 V	-	1	1.5	
t _{h(OUT)}	Data output hold time	2.0 < V _{CC} < 3.6 V	0.5	-	-	

1. Given by characterization, not tested in production.

Table 5-21 ESMC characteristics in DDR mode ⁽¹⁾

Symbol	Parameter	Condition	Minimum	Typical	Maximum	Unit
F(QCK)	SPI clock frequency	2.0 < V _{CC} < 3.6 V	-	-	70	MHz
t _{w(CKH)}	SPI clock high and low time	2.0 < V _{CC} < 3.6 V	t _{CK} /2-0.5	-	t _{CK} /2+1	ns
t _{w(CKL)}			t _{CK} /2-1	-	t _{CK} /2+0.5	
t _{sr(IN)}	Data input setup time on rising edge	2.0 < V _{CC} < 3.6 V	2	-	-	
t _{sf(IN)}	Data input setup time on falling edge	2.0 < V _{CC} < 3.6 V	2	-	-	
t _{hr(IN)}	Data input hold time on rising edge	2.0 < V _{CC} < 3.6 V	5	-	-	

Symbol	Parameter	Condition	Minimum	Typical	Maximum	Unit
$t_{hf(IN)}$	Data input hold time on falling edge	$2.0 < V_{CC} < 3.6 V$	5	-	-	
$t_{vr(OUT)}$	Data output valid time on rising edge	$2.0 < V_{CC} < 3.6 V$	-	-	9	
$t_{vf(OUT)}$	Data output valid time on falling edge	$2.0 < V_{CC} < 3.6 V$	-	-	11	
$t_{hr(OUT)}$	Data output hold time rising edge	$2.0 < V_{CC} < 3.6 V$	2	-	-	
$t_{hf(OUT)}$	Data output hold time falling edge	$2.0 < V_{CC} < 3.6 V$	3	-	-	

1. Given by characterization, not tested in production.

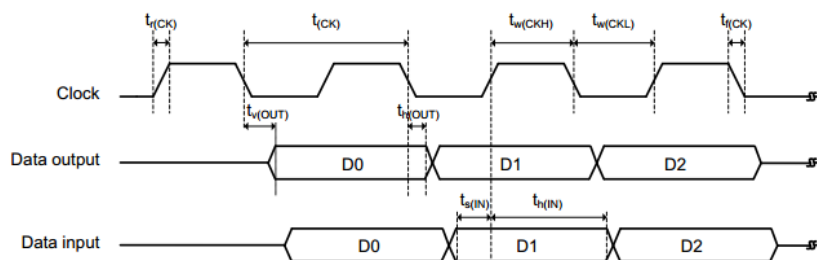

Figure 5-3 ESMC timing diagram – SDR mode

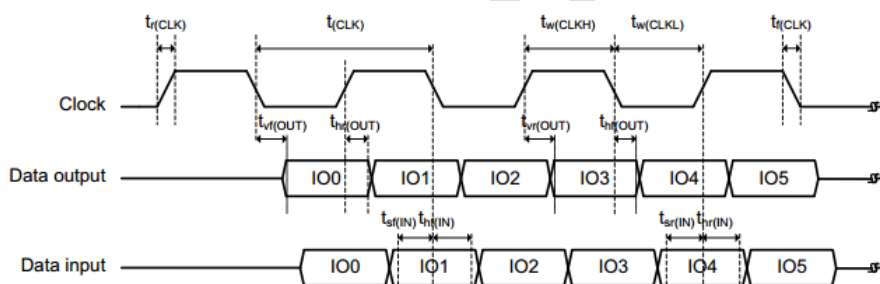

Figure 5-4 ESMC timing diagram – DDR mode2

5.3.12. EMC characteristics

Sensitivity testing is conducted on a sample basis during product characteristic evaluation

EMS (Electromagnetic sensitivity)

When running a simple application (flashing 2 LEDs through the I/O port), the test sample is subjected to 2 types of electromagnetic interference until an error is generated, and the flashing LEDs indicate the generation of the error.

- Electrostatic discharge (ESD) (positive and negative discharge): applied to all pins of the chip until a functional error is generated. This test complies with IEC61000-4-2 standard.
- FTB: A pulse train of transient voltages (forward and reverse) is applied to V_{CC} and V_{SS} through a 100 pF capacitor until a functional error is generated. This test is in accordance with IEC61000-4-4.

A chip reset can restore the system to normal operation.

The test results are listed in the table below. This is a test based on the level and type of EMS defined by AN.

Table 5-22 EMC characteristics

Symbol	Parameter	Condition	Level / Type
V _{FESD}	Voltage limits applied to any I/O pins that cause functional interference	V _{CC} = 3.3 V, T _A = +25 °C, f _{HCLK} = 144 MHz, Compliant with IEC 61000-4-2 standard	2 A
V _{FTB}	Fast transient pulse voltage limits applied through 100 pF capacitors on the V _{CC} and V _{SS} pins that cause functional errors	V _{CC} = 3.3 V, T _A = +25 °C, f _{HCLK} = 144 MHz, Compliant with IEC 61000-4-4 standard	4 A

Design solid software to avoid noise problems

The evaluation and optimization of EMC at the device level is performed in a typical application environment. It should be noted that good EMC performance is closely related to the user application and the specific software. Therefore, it is recommended that users implement EMC optimization of the software and perform EMC-related certification tests.

Software suggestions

The flow of the software must contain controls for program runaway, e.g:

- Corrupted program counter
- Unexpected reset
- Corrupted critical data (control registers, etc...)

Pre-certification experiments

Many common failures (unexpected resets and corrupted program counters) can be reproduced by manually introducing a low level on the NRST or a low level on the crystal pin that lasts for 1 second. When performing ESD tests, voltages beyond the application requirements can be applied directly to the chip, and where unexpected actions are detected, the software part needs to be enhanced to prevent unrecoverable errors from occurring.

EMI (Electromagnetic Interference)

The electromagnetic fields emitted by the device are monitored when performing a simple application (switching 2 LEDs through I/O ports). The test complies with the IEC 61967-2 standard, which specifies the test board and pin load.

Table 5-23 EMICharacteristics

Symbol	Parameter	Condition	Monitoring band	Max vs. [f _{HSE} /f _{HCLK}]			Unit
				8/48 MHz	8/72 MHz	8/108 MHz	
S _{EMI}	Peak value	V _{CC} = 3.3 V, T _A = +25 °C, Compliant with IEC 61967-2 standard	0.1 ~ 2 MHz	-	-	-	dBμV
			2 ~ 30 MHz	-	-	-	
			30 ~ 130 MHz	-	-	-	
			130 MHz ~ 1GHz	-	-	-	

5.3.13. ESD & LU characteristics

Based on three different tests (ESD, LU), stress tests are applied to the chip using specific measurement methods to determine its performance in terms of electrical sensitivity.

Table 5-24 ESD 特性

Symbol	Parameter	Condition	Minimum	Typical	Maximum	Unit
$V_{ESD(HBM)}$	Electrostatic discharge voltage (human model)	$T_A=25\text{ }^\circ\text{C}$; JESD22- A114	-	-	4000	V
$V_{ESD(CDM)}$	Electrostatic discharge voltage (device charging model)	$T_A=25\text{ }^\circ\text{C}$; JESD22-C101	-	-	1000	V
LU	Overcurrent test	$T_A=25\text{ }^\circ\text{C}$; JESD78A	-	-	± 200	mA
	Overpressure test		-	-	5.4	V

5.3.14. I/O current injection characteristics

As a general rule, current injection into I/O pins due to external voltages below VSS or above VCC (for standard, 3 V I/O pins) should be avoided during normal product operation. However, in order to give an indication of the robustness of the microcontroller in case of abnormal injection accidents, sampling is done during device characterization tests.

Functional sensitivity to I/O current injection

When executing simple applications on the device, stress the device by injecting current into I/O pins configured for input float mode. When current is injected into I/O pins (one at a time), the device is checked for functional faults.

Faults are indicated by out-of-range parameters: ADC errors above a certain limit (>5 LSB TUE), current injection on adjacent pins out of specification, or other functional faults (e.g., reset, oscillator frequency deviation).

Table 5-25 I/O current injection sensitivity

Symbol	Parameter	Functional sensitivity		Unit
		Negative current injection	Positive current injection	
I_{INJ}	Injected current on OSC_IN32, OSC_OUT32, PA4, PA5, PC13 pins	0	0	mA
	Injected current on all 5 V tolerance pins	-5	0	
	Injected current on all other pins	-5	5	

5.3.15. EFT characteristics

Table 5-26 EFT characteristics

Symbol	Parameter	Condition	Level	Typical value	Unit
EFT to IO	-	IEC61000-4-4	B	2	KV
EFT to Power	-	IEC61000-4-4	B	4	KV

5.3.16. Port Characteristics

Table 5-27 IO Port Characteristics

Symbol	Parameter	Condition	Minimum	Typical	Maximum	Unit
V _{IL}	Standard I/O input low	2.0 V ≤ V _{CC} ≤ 3.6 V	-0.3	-	0.35 V _{CC} -0.06	V
	5 V-tolerant I/O input low	2.0 V ≤ V _{CC} ≤ 3.6 V	-0.3	-	0.4 V _{CC} -0.04	V
V _{IH}	Standard I/O input high	2.0 V ≤ V _{CC} ≤ 3.6 V	0.6 V _{CC} +0.14	-	V _{CC} +0.3	V
	5 V-tolerant I/O input high	2.0 V ≤ V _{CC} ≤ 3.6 V	0.45 V _{CC} +0.13	-	5.5	V
V _{hys} ⁽¹⁾	Standard I/O Schmitt voltage hysteresis	-	200	-	-	mV
	5 V-tolerant I/O Schmitt voltage hysteresis	-	5% V _{CC}	-	-	mV
V _{Ikg} ⁽²⁾	Input leakage current	V _{SS} ≤ V _{IN} ≤ V _{CC}	-	-	-1	μA
		Standard I/O	-	-	-	
		V _{IN} = 5 V,	-	-	3	μA
		5 V-tolerant I/O	-	-	-	
R _{PU} ⁽³⁾	Internal pull-up resistor	V _{IN} =V _{SS}	30	40	50	kΩ
R _{PD} ⁽³⁾	Internal pull-down resistor	V _{IN} =V _{CC}	30	40	50	kΩ
C _{IO}	I/O pin capacitance	-	-	5	-	pF

1. Guaranteed by design, not tested in production.
2. If there is reverse current backflow on adjacent pins, the leakage current may be higher than the maximum value.
3. The pull-up and pull-down resistors are designed to be implemented as a true resistor in series with a switchable PMOS/NMOS.

Output drive current

GPIO (General Purpose Input/Output Port) can absorb or output up to ±8 mA of current or up to ±20 mA of current (subject to relaxed V_{OL}/V_{OH} specifications.) The three pins PC13, PC14, and PC15 can only absorb or output ±3 mA of current. When PC13, PC14, and PC15 are used as output functions, the I/O speed cannot exceed 2 MHz at an output load of 30 pF.

In user applications, the number of I/O pins must be such that the drive current cannot exceed the absolute maximum rating given by the absolute maximum rating of:

- The sum of the currents drawn from V_{CC} by all I/O ports, plus the maximum operating current drawn by the MCU on V_{CC}, must not exceed the absolute maximum rating I_{VCC}.
- The sum of the currents absorbed by all I/O ports and flowing from V_{SS}, plus the maximum operating current flowing from the MCU on V_{SS}, must not exceed the absolute maximum rating I_{VSS}.

Output Voltage

Unless otherwise noted, the parameters listed in the table below were obtained from tests conducted under general operating conditions TA using ambient temperature and VCC supply voltage conditions.

Table 5-28 Output Voltage Characteristics

Symbol	Parameter	Condition	Minimum	Typical	Maximum ⁽²⁾	Unit
V _{OL}	Output low, 8 pins absorb current simultaneously	2.7 V ≤ V _{CC} ≤ 3.6 V, I _{IO} = +8 mA	-	-	0.4	V
		2.7 V ≤ V _{CC} ≤ 3.6 V, I _{IO} = +20 mA ⁽¹⁾	-	-	1.3	
		2.0 V ≤ V _{CC} ≤ 2.7 V, I _{IO} = +6 mA ⁽¹⁾	-	-	0.4	
V _{OH}	Output high, 8 pins simultaneously output current	2.7 V ≤ V _{CC} ≤ 3.6 V, I _{IO} = +8 mA	V _{CC} -0.4	-	-	
		2.7 V ≤ V _{CC} ≤ 3.6 V, I _{IO} = +20 mA ⁽¹⁾	V _{CC} -1.3	-	-	
		2.0 V ≤ V _{CC} ≤ 2.7 V, I _{IO} = +6 mA ⁽¹⁾	V _{CC} -0.4	-	-	

1. The IO types can be found in the terminology and symbols of the pin definitions.
2. Data is based on test results and is not tested in production.

5.3.17. NRST pin characteristics

Table 5-29 NRST pin characteristics

Symbol	Parameter	Condition	Minimum	Typical	Maximum	Unit
V _{IL(NRST)} ⁽¹⁾	NRST input low level	-	-0.5	-	0.8	V
V _{IH(NRST)} ⁽¹⁾	NRST input high level	-	2	-	V _{CC} +0.5	
V _{hys(NRST)}	NRST Schmidt Hysteresis Voltage	-	-	200	-	mV
R _{PU}	Weak pull-up equivalent resistance ⁽²⁾	V _{IN} = V _{SS}	30	40	50	kΩ
V _{F(NRST)} ⁽¹⁾	NRST input filter pulse	-	-	-	100	ns
V _{NF(NRST)} ⁽¹⁾	NRST input non-filtered pulse	-	300	-	-	ns

1. Guaranteed by design, not tested in production.
2. The pull-up resistor is designed as a true resistor in series with a switchable PMOS implementation. This PMOS/NMOS switch has a very small resistance (about 10%).

5.3.18. ADC characteristics

Table 5-30 ADC characteristics

Symbol	Parameter	Condition	Minimum vaule	Typical	Maximum	Unit
V _{CCA} ⁽³⁾	Supply voltage	-	1.8	-	3.6	V
V _{REF+}	Positive reference voltage	-	1.8	-	V _{CCA}	V
I _{VCCA}	V _{CCA} Pin Current	f _{ADC} = 16 MHz	-	280	370 ⁽¹⁾	μA
I _{VREF}	V _{REF} Pin Current	f _{ADC} = 16 MHz	-	8	10 ⁽¹⁾	μA
f _{ADC}	ADC clock frequency	-	0.8	-	16	MHz
f _S ⁽²⁾	Sampling rate	-	0.05	-	1	MHz
V _{AIN}	Conversion voltage range ⁽³⁾	-	0 (V _{SSA} or V _{REF-} connected to ground)		V _{REF+}	V
R _{AIN} ⁽²⁾	External input resistance	-	-	-	30.9	kΩ
R _{ADC} ⁽²⁾	Sampling switch resistance	-	-	-	1.6	kΩ
C _{ADC} ⁽²⁾	Internal sampling and holding capacitors	-	-	-	8	pF
t _{CAL} ⁽²⁾	Calibration time	f _{ADC} = 16 MHz	5.6875~8.75			μs
		-	91 (sampling time of 1clk) ~ 140 (sampling time of 8clk)			1/f _{ADC}
t _S ⁽²⁾	Sampling time	f _{ADC} = 16 MHz	0.218	-	14.968	μs
		-	3.5	-	239.5	1/f _{ADC}
t _{STAB} ⁽²⁾	Power-up stabilization time	-	0	0	1	μs

Symbol	Parameter	Condition	Minimum vaule	Typical	Maximum	Unit
$t_{CONV}^{(2)}$	Total conversion time (including sampling time)	$f_{ADC} = 16 \text{ MHz}$	1	-	15.75	μs
		-	16 ~ 252 (sampled t_s + 12.5 successive approximations)			$1/f_{ADC}$

1. Guaranteed by design, not tested in production.
2. Data is based on test results and is not tested in production.
3. Some package forms V_{REF+} can be internally connected to V_{CCA} , V_{REF-} can be internally connected to V_{SSA} , please refer to the pin definition for details.

Table 5-31 R_{AIN} max for $f_{ADC} = 16 \text{ MHz}^{(1)}$

T_s (Periodicity)	t_s (μs)	R_{AIN} max (kW)
3.5	0.21	0.3
5.5	0.34	1.9
7.5	0.46	3.5
13.5	0.84	8.3
28.5	1.78	20.4
41.5	2.59	30.9
134.5	8.41	NA
239.5	15.96	NA

1. Guaranteed by design, not tested in production.

Table 5-32 ADC Accuracy⁽¹⁾⁽²⁾⁽³⁾⁽⁴⁾

Symbol	Parameter	Test condition	Typical	Maximum ⁽³⁾	Unit
ET	Total unadjusted error	$1.8 \text{ V} < V_{DDA}=V_{REF+} < 3.6 \text{ V}$; $f_{ADC} = 16 \text{ MHz}; f_s \leq 1 \text{ MSps}$; $T_A = \text{entire range}$	7.5	15	LSB
EO	Offset error	$V_{DDA}=V_{REF+} 3.3 \text{ V}$; $f_{ADC} = 16 \text{ MHz}; f_s \leq 1 \text{ MSps}$ $T_A = \text{entire range}$	2	4	LSB
		$1.8 \text{ V} < V_{DDA}=V_{REF+} < 3.6 \text{ V}$; $f_{ADC} = 16 \text{ MHz}; f_s \leq 1 \text{ MSps}$ $T_A = \text{entire range}$	2	6	
EG	Gain error	$V_{DDA}=V_{REF+} 3.3 \text{ V}$; $f_{ADC} = 16 \text{ MHz}; f_s \leq 1 \text{ MSps}$ $T_A = \text{entire range}$	4	5	LSB
		$1.8 \text{ V} < V_{DDA}=V_{REF+} < 3.6 \text{ V}$; $f_{ADC} = 16 \text{ MHz}; f_s \leq 1 \text{ MSps}$ $T_A = \text{entire range}$	4	8	
ED	Differential linearity error	$1.8 \text{ V} < V_{DDA}=V_{REF+} < 3.6 \text{ V}$; $f_{ADC} = 16 \text{ MHz}; f_s \leq 1 \text{ MSps}$ $T_A = \text{entire range}$	1.2	1.5	LSB
EL	Integral linearity error	$1.8 \text{ V} < V_{DDA}=V_{REF+} < 3.6 \text{ V}$; $f_{ADC} = 16 \text{ MHz}; f_s \leq 1 \text{ MSps}$ $T_A = \text{entire range}$	4	6	LSB

1. Data is based on test results and is not tested in production.

- Calibration is done prior to ADC testing.
- ADC Accuracy vs. Reverse Injected Current: Reverse current injection on any standard analog input pin needs to be avoided, as it can significantly degrade the accuracy of the conversion being performed on the other analog input pin. It is recommended to add a Schottky diode (between the pin and ground) to the standard analog pin where the reverse injection current is likely to occur. If the forward injection current is within the $I_{INJ(PIN)}$ and $\Sigma I_{INJ(PIN)}$ ranges given in the I/O current injection characteristics, it will not affect the ADC accuracy.
- Guaranteed by characteristic evaluation, not tested in production.

5.3.19. Temperature sensor characteristics

Table 5-33 Temperature sensor characteristics

Symbol	Parameter	Minimum	Typical	Maximum	Unit
$T_L^{(1)}$	V_{SENSE} linearity with respect to temperature	-	± 1	± 2	$^{\circ}\text{C}$
Avg_Slope ⁽¹⁾	Average slope	2.0	2.2	2.4	mV/ $^{\circ}\text{C}$
$V_{25}^{(1)}$	Voltage at 25 $^{\circ}\text{C}$	0.582	0.6	0.618	V
$t_{START}^{(2)}$	Establishment time	4	-	10	μs
$T_{S_temp}^{(2)(3)}$	ADC sampling time when reading temperature	-	-	17.1	μs

- Guaranteed by design, not tested in production.
- The data is based on assessment results and is not tested in production.
- The minimum sampling time can be determined by the application through multiple cycles.

5.3.20. Built-in reference voltage characteristics

Table 5-34 Built-in reference voltage characteristics

Symbol	Parameter	Minimum	Typical	Maximum	Unit
V_{REFINT}	Internal reference voltage	1.17	1.2	1.23	V
$T_{S_vrefint}^{(1)}$	ADC sampling time when reading the internal reference voltage	-	5.1	17.1	μs
V_{RERINT}	Internal reference voltage deviation over the temperature range	-	-	10	mV
T_{Coeff}	Temperature coefficient	-100	-	100	ppm/ $^{\circ}\text{C}$

- Guaranteed by design, not tested in production.

5.3.21. Timer characteristics

Table 5-35 Timer characteristics

Symbol	Parameter	Condition	Minimum	Maximum	Unit
$t_{res(TIM)}$	Timer resolution time	-	1	-	$t_{TIMxCLK}$
		$f_{TIMxCLK} = 144 \text{ MHz}$	-	-	ns
f_{EXT}	Timer external clock frequency on CH1 to CH4	-	0	$f_{TIMxCLK}/2$	MHz
		$f_{TIMxCLK} = 144 \text{ MHz}$	-	-	MHz
Res_{TIM}	Timer resolution	-	-	16	bit
$t_{COUNTER}$	16-bit counter clock period when internal clock is selected	-	1	65536	$t_{TIMxCLK}$
		$f_{TIMxCLK} = 144 \text{ MHz}$	-	-	μs
t_{MAX_COUNT}	Maximum possible count	-	-	65536×65536	$t_{TIMxCLK}$
		$f_{TIMxCLK} = 144 \text{ MHz}$	-	-	s

Table 5-36 IWDG characteristics (Clock Select LSI)

Prescaler	PR[2:0]	Minimum overflow	Maximum overflow	Unit
/4	0	0.122	499.712	ms
/8	1	0.244	999.424	
/16	2	0.488	1998.848	
/32	3	0.976	3997.696	
/64	4	1.952	7995.392	
/128	5	3.904	15990.784	
/256	6 or 7	7.808	31981.568	

Table 5-37 WWDG characteristics (clock selection 48 MHz PCLK)

Prescaler	WDGTB[1:0]	Minimum overflow	Maximum overflow	Unit
1*4096	0	0.085	5.461	ms
2*4096	1	0.171	10.923	
4*4096	2	0.341	21.845	
8*4096	3	0.683	43.691	

5.3.22. Communication port characteristics

5.3.22.1. I²C Interface Features

The I²C interface conforms to the standard I²C communication protocol with the following limitations: SDA and SCL are not 'true' pins and when configured as open-drain outputs, the PMOS tube between the pinout and VCC is turned off, but still present.

Table 5-38 I²C Interface Features

Symbol	Parameter	Standard I ² C ⁽¹⁾		Fast I ² C ⁽¹⁾⁽²⁾		Unit
		Minimum	Maximum	Minimum	Maximum	
t _w (SCLL)	SCL clock low time	4.7	-	1.3	-	μs
t _w (SCLH)	SCL clock high time	4	-	0.6	-	μs
t _{su} (SDA)	SDA build time	250	-	100	-	ns
t _h (SDA)	SDA data retention time	-	3450 ⁽³⁾	-	900 ⁽³⁾	
t _r (SDA) /t _r (SDL)	SDA and SCL rise time	-	1000	-	300	
t _f (SDA) /t _f (SDL)	SDA and SCL down time	-	300	-	300	
t _h (STA)	Start condition hold time	4	-	0.6	-	μs
t _{su} (STA)	Repeated start condition establishment time	4.7	-	0.6	-	
t _{su} (STO)	Stop condition establishment time	4	-	0.6	-	
t _w (STO:STA)	Time from stop condition to start condition (bus idle)	4.7	-	1.3	-	
C _b	Capacitive load per bus	-	400	-	400	pF
t _{sp}	Noise filtering pulse width	0	50 ⁽⁴⁾	0	50 ⁽⁴⁾	μs

1. Guaranteed by design, not tested in production.
2. To achieve the maximum frequency for standard mode I²C, f_{PCLK1} must be greater than 2 MHz. f_{PCLK1} must be greater than 4 MHz to achieve the maximum frequency for fast mode I²C.

- A hold time of at least 300 nS on the SDA signal must be ensured internally to avoid data changes on the SDA bus during SCL low at data output.
- The noise pulse width is suppressed by the analog filter.

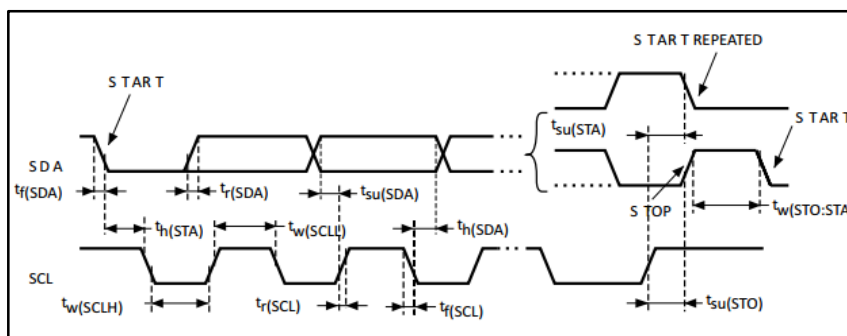
Figure 5-5 I²C Bus Timing Diagram

5.3.22.2. SPI Interface characteristics

Table 5-39 SPI Interface characteristics

Symbol	Parameter	Condition	Minimum	Typical	Maximum	Unit
f_{SCK} $1/t_c(SCK)$	SPI clock frequency	Master Mode 2.7~3.6 V	-	-	36	MHz
		Master Mode 1.8~3.6 V	-	-	36	
		Slave mode 2.7~3.6 V	-	-	36	
		Slave mode 1.8~3.6 V	-	-	36	
$t_r(SCK)$ $t_f(SCK)$	SPI clock rise/fall time	Load capacitance: C= 30 pF	-	-	5	ns
DuCy(SCK)	SPI Slave Mode Input Clock Duty Cycle	Slave mode	45	-	55	%
$t_{su}(NSS)$	NSS build time	Slave mode	$4t_{PCLK}$	-	-	ns
$t_h(NSS)$	NSS hold time	Slave mode	$2t_{PCLK}$	-	-	
$t_w(SCKH)$ $t_w(SCKL)$	SCK high/low time	Master Mode, presc = 4	$2T_{pclk}-1$	$2T_{pclk}$	$2T_{pclk}+1$	
$t_{su}(MI)$	Data entry build time	Master Mode presc = 4	$T_{pclk} + 4$ ⁽¹⁾	-	-	
$t_{su}(SI)$		Slave mode presc = 4	3	-	-	
$t_h(MI)$	Data input hold time	Master Mode	4	-	-	
$t_h(SI)$		Slave mode	$T_{pclk} + 4$	-	-	
$t_a(SO)$	Data output access time	Slave mode presc = 4	0	-	$3T_{pclk}$	
$t_{dis}(SO)$	Data output prohibition time	Slave mode	$2T_{pclk} + 5$	-	$4T_{pclk} + 5$	
$t_v(SO)$	Data output validity time	Slave mode 2.7~3.6 V presc = 4	0	-	12 or $1.5T_{pclk}$ ⁽²⁾	
		Slave mode 1.8~3.6 V presc = 4	0	-	18 or $1.5T_{pclk}$ ⁽²⁾	
$t_v(MO)$		Master Mode (after enable edge)	-	3.5	4.5	
$t_h(SO)$	Data output hold time	Slave mode (after enable edge) presc = 4	0 ⁽³⁾	-	-	
$t_h(MO)$		Master Mode (after enable edge)	2	-	-	

- Master generates 1 PCLK receive control signal before the receive edge.

- The Slave has a maximum of 1 PCLK delay based on the SCK send edge, and 1.5 PCLK is defined considering the IO delay, etc.
- The Slave updates the data before the send edge if the SCK duty cycle sent by the Master is wide between the receive edge and the send edge.

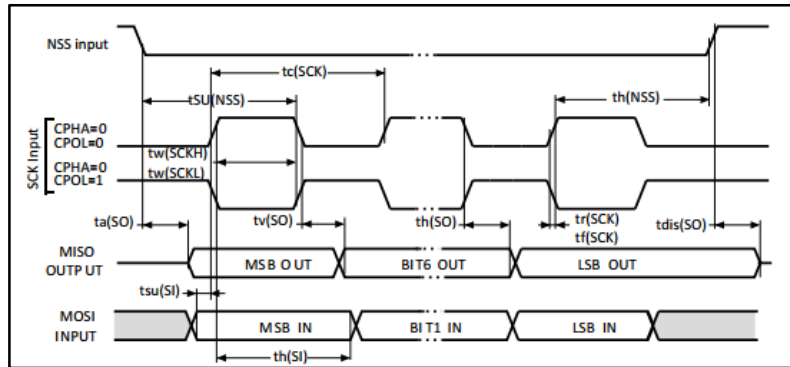

Figure 5-6 SPI Timing Diagram - Slave Mode and CPHA = 0

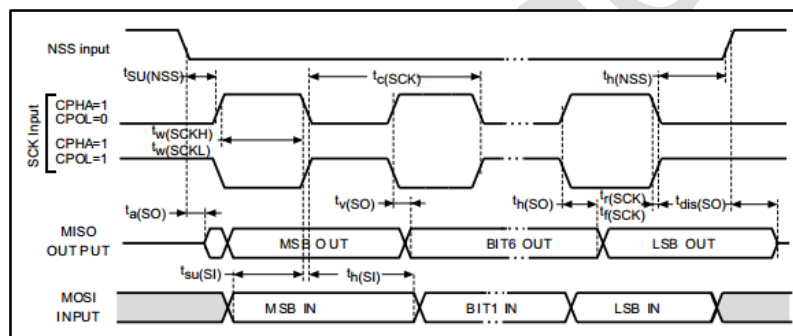

Figure 5-7 SPI Timing Diagram - Slave Mode and CPHA = 1(1)

- Measurement points set at CMOS levels: 0.3V_{CC} and 0.7V_{CC}

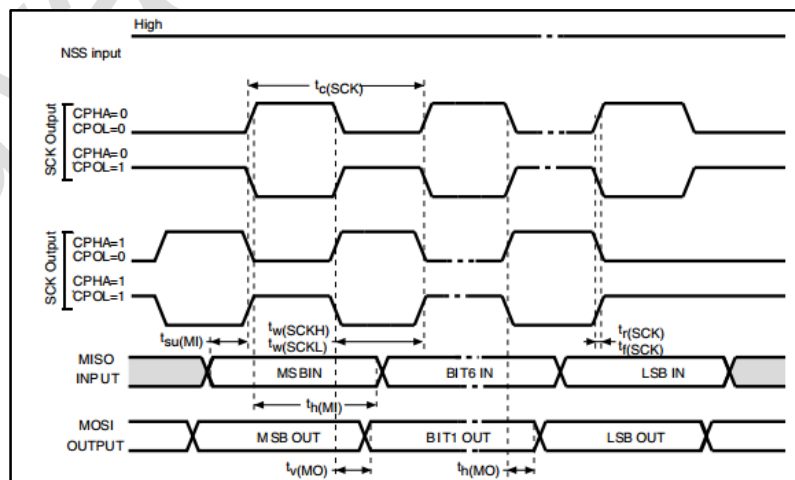

Figure 5-8 SPI Timing Diagram-Master Mode(1)

- Measurement point set at CMOS level: 0.3V_{CC} and 0.7V_{CC}

5.3.22.3. I2S Interface characteristics

Table 5-40 I2SInterface characteristics

Symbol	Parameter	Condition	Minimum	Maximum	Unit	
f _{MCLK}	I2S Master Clock Output	-	256x8 K	256x $F_s^{(1)}$	MHz	
f _{CK} 1/t _{c(CK)}	I2S Clock Frequency	Master mode data	-	64x F_s	MHz	
		Slave mode data	-	64x F_s		
D _{CK}	I2S Clock Duty Cycle	Slave mode reception	30	70	%	
t _{r(CK)} t _{f(CK)}	I2S Clock up/down time	Capacitive load C _L = 50 pF	-	8	ns	
t _{v(WS)}	W _S Effective time	Master mode	-	2		
t _{h(WS)}	W _S Holding time	Master mode	3	-		
		Slave mode	2	-		
t _{su(W_S)}	W _S Establishment time	Slave mode	4	-		
t _{su(SD_MR)}	Data entry build time	Master receiver	3	-		
t _{su(SD_SR)}		Slave receiver	4	-		
t _{h(SD_MR)}	Data input hold time	Master receiver	5	-		
t _{h(SD_SR)}		Slave receiver	2	-		
t _{v(SD_ST)}	Data output validity time	Slave receiver (After enable edge)	2.7-3.6 V	-		15
			2.0-3.6 V	-		22
t _{v(SD_MT)}		Master receiver (After enable edge)	-	2		
t _{h(SD_ST)}	Data output hold time	Slave receiver (After enable edge)	7	-		
t _{h(SD_MT)}		Master receiver (After enable edge)	1	-		

1. 256x F_s up to 49.152 MHz

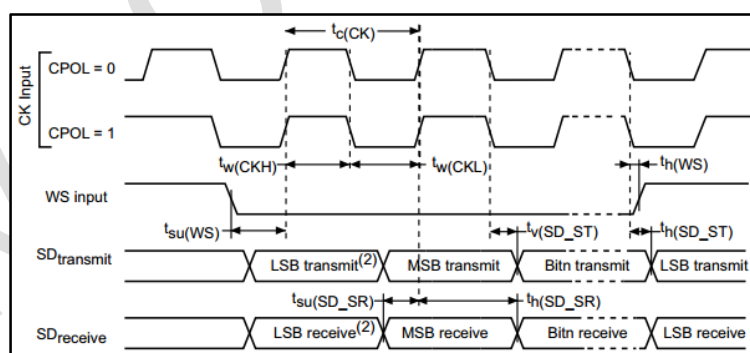

Figure 5-9 I2S Slave mode timing diagram (Philips protocol) ⁽¹⁾

1. Measurement points are done at CMOS levels: 0.3 × V_{CC} and 0.7 × V_{CC}.
2. LSB transmit/receive of the previously transmitted byte. No LSB transmit/receive is sent before the first byte.

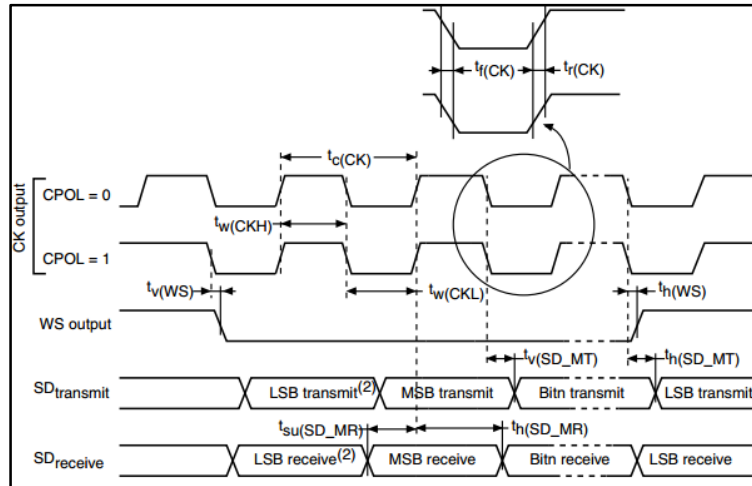

Figure 5-10 I2S Master mode timing diagram (Philips protocol) ⁽¹⁾

1. Guaranteed by characterization results.
2. LSB transmit/receive of the previously transmitted byte. No LSB transmit/receive is sent before the first byte.

5.3.22.4. USB characteristics

Table 5-41 USB Startup time

Symbol	Parameter	Maximum	Unit
$t_{START}^{(1)}$	USB transceiver startup time	1	μs

1. Guaranteed by design

Table 5-42 USB DC Characteristics

Symbol	Parameter	Condition	Minimum ⁽¹⁾	Maximum ⁽¹⁾	Unit
V_{CC}	USB operating voltage ⁽²⁾	-	3.0 ⁽³⁾	3.6	V
$V_{DI}^{(4)}$	Differential input sensitivity	I(USB_DP, USB_DM)	0.2	-	
$V_{CM}^{(4)}$	Differential common mode range	Includes VDI range	0.8	2.5	
$V_{SE}^{(4)}$	Single-ended receiver threshold	-	1.3	2	
Output Level					
V_{OL}	Static output low level	$R_L = 1.5\text{ k}\Omega$ connected to 3.6 V ⁽⁵⁾	-	0.3	V
V_{OH}	Static output high level	$R_L = 15\text{ k}\Omega$ connected to $V_{SS}^{(5)}$	2.8	3.6	

1. All voltage measurements are based on the ground at the device end.
2. The USB function of this product can be as low as 2.7 V. However, the complete USB electrical characteristics cannot be guaranteed in the range of V_{CC} voltage reduction to 2.7~3.0 V.
3. Guaranteed by evaluation, not tested in production.
4. R_L is the load connected to the USB driver.

Table 5-43 USB Full speed electrical characteristics ⁽¹⁾

Symbol	Parameter	Condition	Minimum	Maximum	Unit
t_r	Rise time ⁽²⁾	$C_L \leq 50$ pF	4	20	ns
t_f	Descent time ⁽²⁾	$C_L \leq 50$ pF	4	20	ns
$t_{r/m}$	Rise and fall time match	t_r/t_f	90	110	%
V_{CRS}	Output signal crossover voltage	-	1.3	2.0	V

1. Guaranteed by design, not tested in production.
2. Measurement data signals from 10% to 90%.

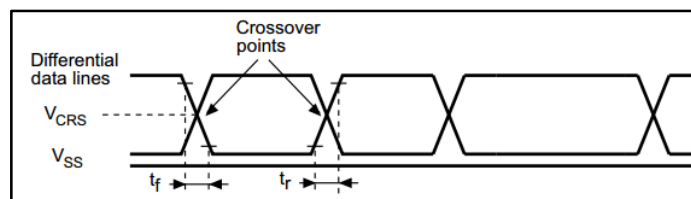

Figure 5-11 USB Timing: Data Signal Rise and Fall Time Definition

5.3.23. SD/SDIO MMCCard host interface characteristics

Table 5-44 SD/MMC characteristics

Symbol	Parameter	Condition	Minimum	Maximum	Unit
f_{PP}	Clock frequency in data transfer mode	$C_L \leq 30$ pF	0	48	MHz
$t_{W(CKL)}$	Clock low time	$f_{PP} = 48$ MHz	8.5	-	ns
$t_{W(CKH)}$	Clock High Time	$f_{PP} = 48$ MHz	8.3	-	
CMD, D input in MMC and SD HS modes (based on CK)					
t_{ISU}	Input build time	$f_{PP} = 48$ MHz	3.5	-	ns
t_{IH}	Input hold time	$f_{PP} = 48$ MHz	0	-	
CMD, D output in MMC and SD HS modes (based on CK)					
t_{OV}	Output effective time	$f_{PP} = 48$ MHz	-	7	ns
t_{OH}	Output hold time	$f_{PP} = 48$ MHz	3	-	
CMD, D input in SD default mode (with CK as reference)					
T_{ISUD}	Input build time	$f_{PP} = 24$ MHz	1.5	-	ns
t_{IHD}	Input hold time	$f_{PP} = 24$ MHz	0.5	-	
CMD, D output in SD default mode (with CK as reference)					
t_{OVD}	Output valid default time	$f_{PP} = 24$ MHz	-	6.5	ns
t_{OHD}	Output maintains default time	$f_{PP} = 24$ MHz	3.5	-	

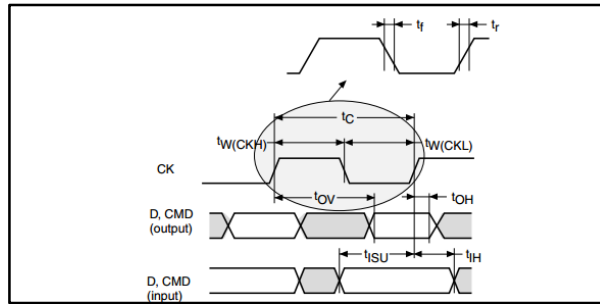

Figure 5-12 SDIO High speed mode

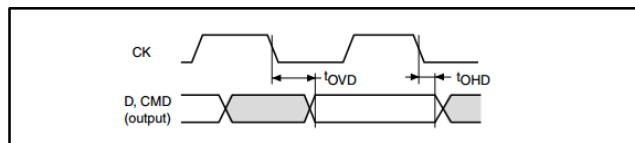

Figure 5-13 SD Default Mode

5.3.24. CANFD Interface characteristics

For the characteristics of the input/output multiplexing function pins (CANFD_TX and CANFD_RX), see the IO Port Characteristics chapter.

6. Package Information

6.1. LQFP100 Package Size

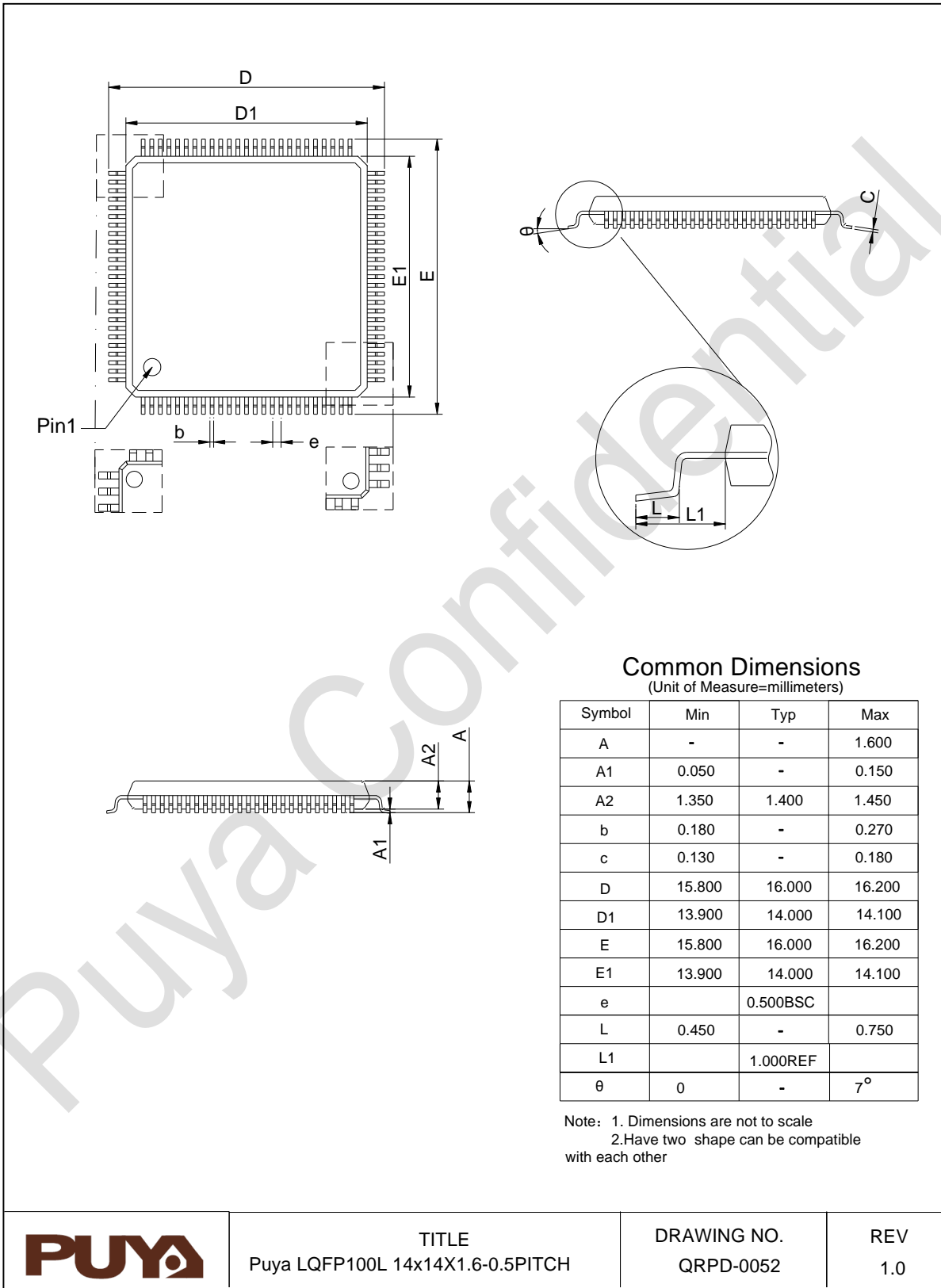

6.2. LQFP64 Package Size

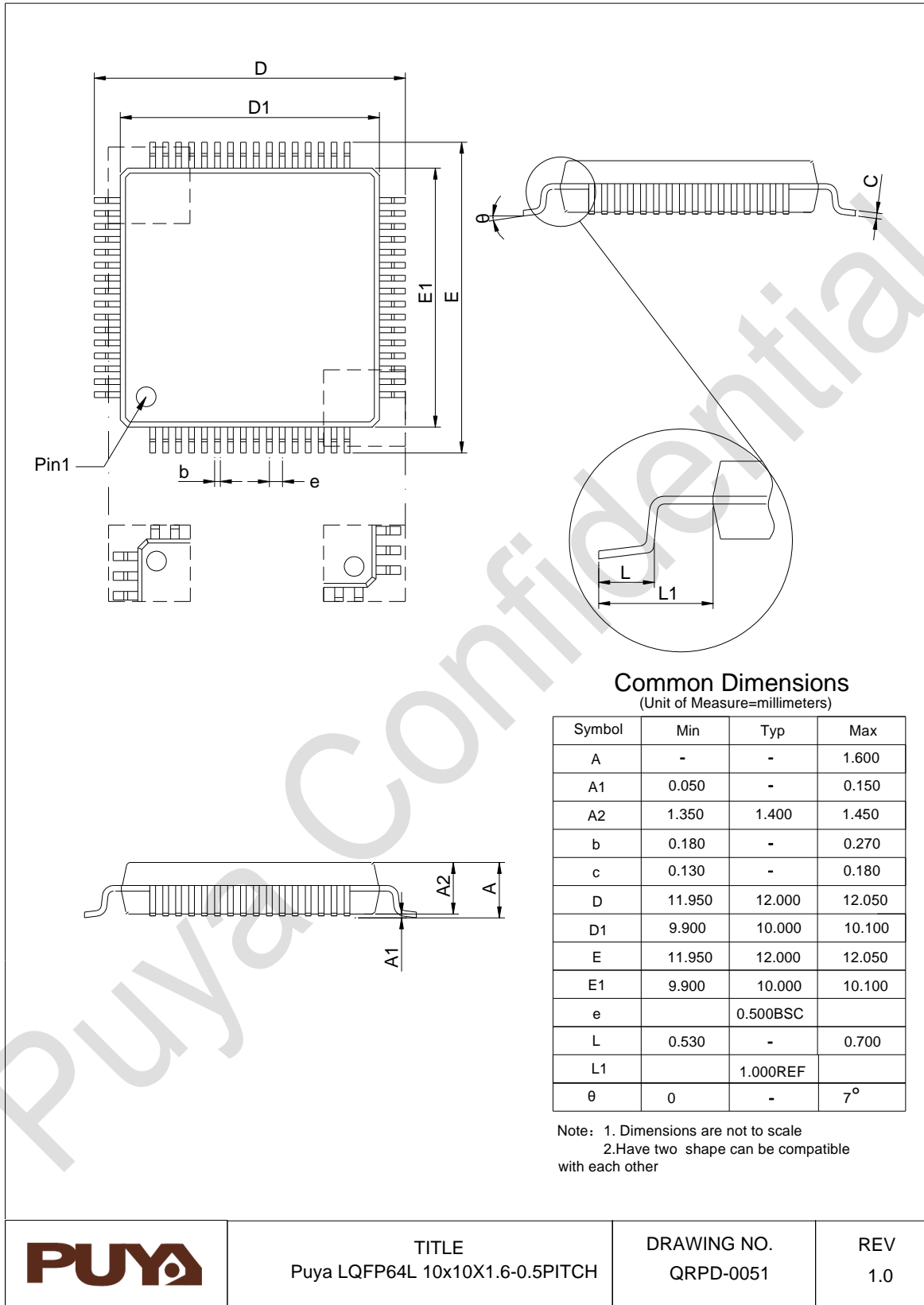

6.3. LQFP48 Package Size

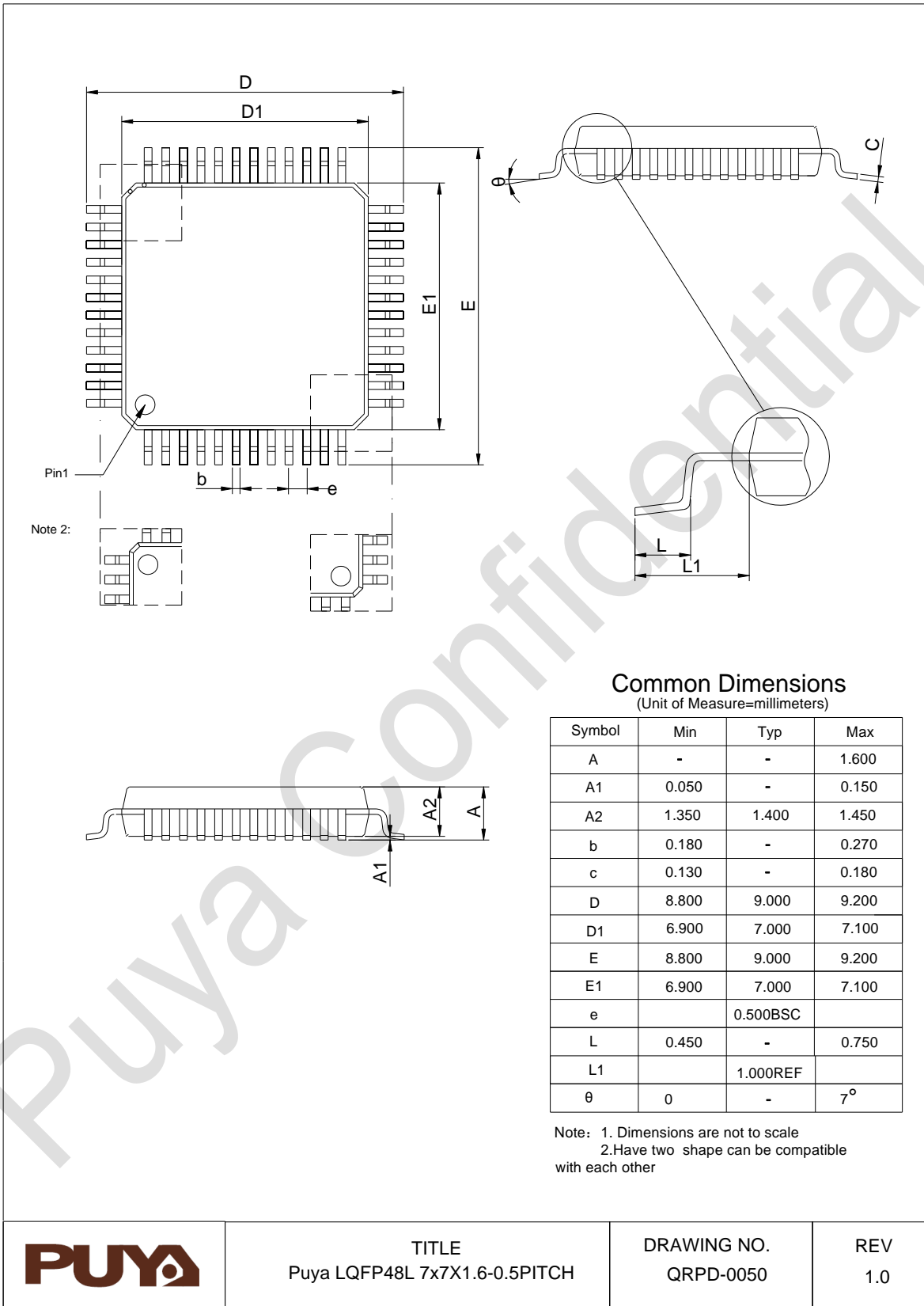

	<p>TITLE Puya LQFP48L 7x7X1.6-0.5PITCH</p>	<p>DRAWING NO. QRPD-0050</p>	<p>REV 1.0</p>
---	--	----------------------------------	--------------------

6.4. QFN48 Package Size

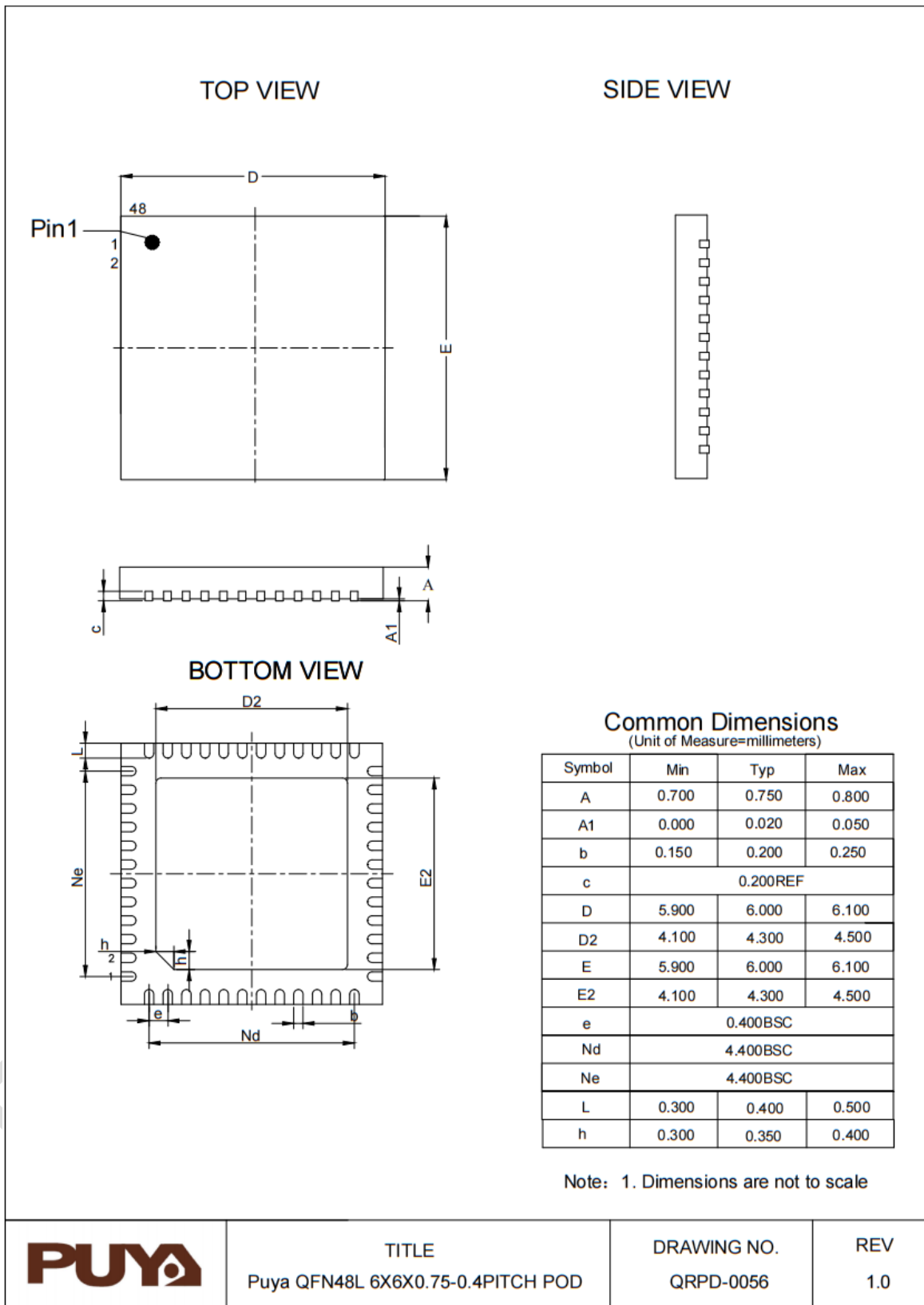

6.5. QFN32 (4*4) Package Size

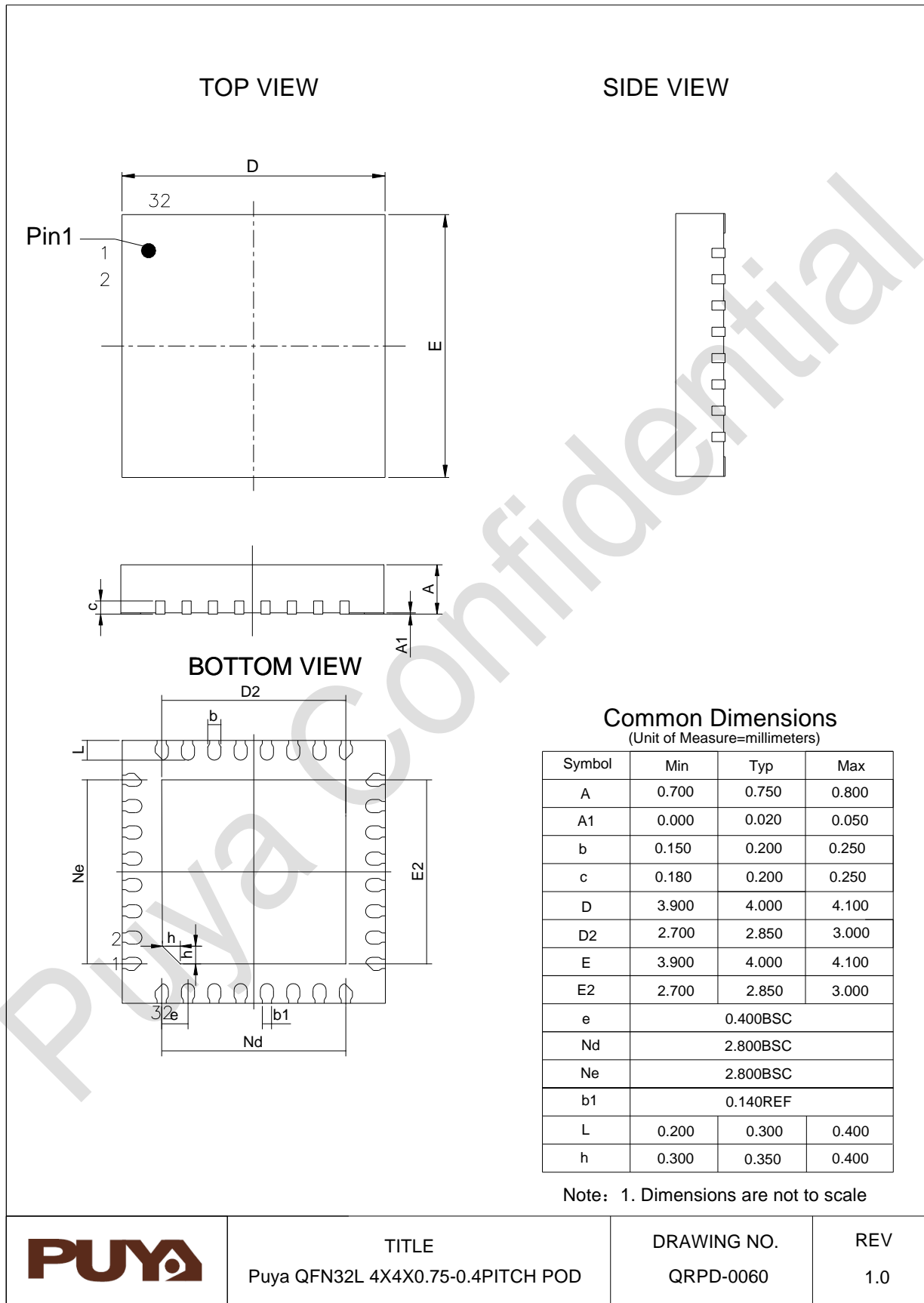

7. Ordering Information

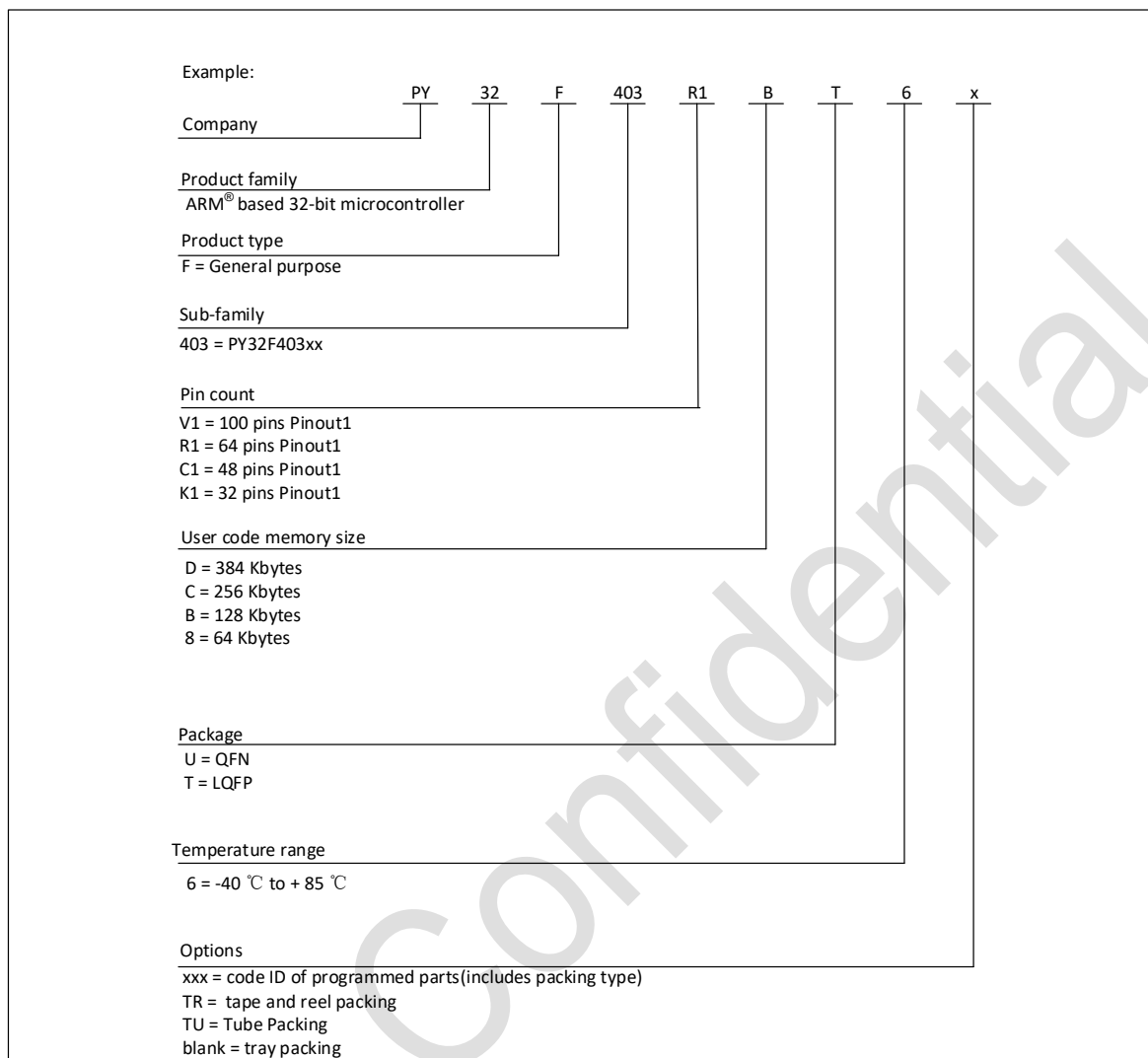

8. Updated History

Version	Date	Updated record
V1.0	2023.08.30	1. First version
V1.1	2024.01.12	1. Update Ordering Information
V1.2	2024.01.29	1. Update Figure 3-6 QFN32 PY32F403Kx Pinout1
V1.3	2024.05.09	<ol style="list-style-type: none"> 1. Add QFN48 package 2. Update Table 1-1 3. Update 2.8.1 Power supply block diagram 4. Update Table 5-4 General working conditions 5. Update Table 5-39 SPI Interface characteristics



Puya Semiconductor Co., Ltd.

IMPORTANT NOTICE

Puya reserve the right to make changes, corrections, enhancements, modifications to Puya products and/or to this document at any time without notice. Purchasers should obtain the latest relevant information of Puya products before placing orders.

Puya products are sold pursuant to terms and conditions of sale in place at the time of order acknowledgement.

Purchasers are solely responsible for the choice and use of Puya products. Puya does not provide service support and assumes no responsibility when products that are used on its own or designated third party products.

Puya hereby disclaims any license to any intellectual property rights, express or implied.

Resale of Puya products with provisions inconsistent with the information set forth herein shall void any warranty granted by Puya.

Any with Puya or Puya logo are trademarks of Puya. All other product or service names are the property of their respective owners.

The information in this document supersedes and replaces the information in the previous version.

Puya Semiconductor Co., Ltd. – All rights reserved